



February 2, 2021

A Design-Build Project

I-95 CITY OF RICHMOND BRIDGE SUPERSTRUCTURE REPLACEMENT AND REHABILITATION BUNDLING

UPC 111300 (U000-127-023, P101, R201, C501, B601; STP-BR04(287))

UPC 111294 (0064-127-022, P101, B661; NHPP-064-3(510))

UPC 113375 (0250-127-050, P101, R201, C501; NHPP-BR04(307))

UPC 113388 (0004-127-051, P101, R201, C501; NHPP-BR04(308))

7TH STREET BRIDGE

CONTRACT ID NUMBER: C00111300DB107





12001 GUILFORD ROAD | ANNAPOLIS JUNCTION, MD 20701
BALTIMORE 401.792.9400 | WASHINGTON 301.953.0900
FAX 301.953.0384

3.2 | Letter of Submittal

February 2, 2021

Commonwealth of Virginia
Department of Transportation (VDOT)
1401 E. Broad Street
Richmond, VA 23219
Attention: Joseph A. Clarke, PE, DBIA (APD Division)

RE: Design-Build | I-95 City of Richmond Bridge Superstructure Replacement and Rehabilitation Bundling | UPC (State Project Nos.: Federal Project Nos.): UPC 111300 (U000-127-023, P101, R201, C501, B601, STP-BR04(287)) UPC 111294 (0064-127-022, P101, B661; NHPP-064-3(510)) UPC 113375 (0250-127-050, P101, R201, C501; NHPP-BR04(307)) UPC 113388 (0004-127-051, P101, R201, C501; NHPP-BR04(308)) 7th Street Bridge | Contract ID No: C00111300DB107

Dear Mr. Clarke:

3.2.1 Corman Kokosing Construction Company (Corman Kokosing), 12001 Guilford Road, Annapolis Junction, MD 20701, is the legal entity who will execute the contract with Department of Transportation (VDOT).

3.2.2 Point of Contact	Secondary Point of Contact	3.2.3 Principal Officer of Corman Kokosing
<p>Ryan Gorman, PE, DBIA Regional Vice President of Alternative Contracting Corman Kokosing Construction Co. 12001 Guilford Road Annapolis Junction, MD 20701 804-400-4521 Cell rgorman@kokosing.biz</p>	<p>Chris Rutkai, PE Senior Area Manager Corman Kokosing Construction Co. 12001 Guilford Road Annapolis Junction, MD 20701 240-581-9577 Cell crutkai@kokosing.biz</p>	<p>Gregory A. Hamilton, PE, DBIA Regional Senior Vice President Corman Kokosing Construction Co. 12001 Guilford Road Annapolis Junction, MD 20701 301-953-0900 614-207-0716 Cell gah@kokosing.biz</p>

3.2.4 Corporate Structure: Corman Kokosing will be the design-build contracting entity for this project. We are a corporation titled in Ohio who will be the sole major participant firm and responsible party to the design-build contract with Virginia Department of Transportation (VDOT). Corman Kokosing will hold all financial responsibility for the contract with no liability limitations.

3.2.5 Lead Contractor: Corman Kokosing Construction Company | **Lead Designer:** Whitman, Requardt and Associates, LLP

3.2.6 Affiliated and/or Subsidiary Companies Table (Attachment 3.2.6) is in the Appendix.

3.2.7 Certification Regarding Debarment Forms (Attachments 3.2.7(a) and 3.2.7(b)) are in the Appendix.

3.2.8 Corman Kokosing’s VDOT Prequalification (C3607-Active) evidence is in the Appendix.

3.2.9 Surety Letter is in the Appendix.

3.2.10 SCC and DPOR information are in **Attachment 3.2.10** and supporting documentation are in the Appendix.

3.2.11 Corman Kokosing is committed to achieving a 9% DBE participation goal for the entire value of the contract.

Sincerely,

CORMAN KOKOSING CONSTRUCTION COMPANY

Gregory A. Hamilton, PE, DBIA
Regional Sr. Vice President

3.3 TEAM STRUCTURE

With a Design-Build portfolio of over \$3 billion, \$700 million directly for VDOT, Corman Kokosing Construction Company (Corman Kokosing) comes to VDOT with the hands-on experience and highly-qualified personnel to execute the design and construction and mitigate the risks of the I-95 City of Richmond Bridge Superstructure Replacement and Rehabilitation Bundling Design-Build project. Corman Kokosing has successfully delivered 25 Design-Build roadway and bridge projects, many similar in complexity to this project. VDOT Design-Build projects (with some setting a precedent regarding the first of its kind in Virginia) include:

- **I-64 Southside Widening and High-Rise Bridge Phase 1, Chesapeake, VA:** *VDOT's first use of ATCs in the selection process and was the largest VDOT Design-Build project to date when awarded*
- **Route 29 Solutions Widening Rio Road and Berkmar Drive Extension, Albemarle County, VA:** *VDOT's first project with a Responsible Charge Engineer as a Key Personnel and included Accelerated Bridge Construction (ABC)*
- **Military Highway Continuous Flow Intersection (CFI), Norfolk, VA:** *Virginia's first CFI*
- **I-64/Route 15 Diverging Diamond Interchange (DDI), Zion Crossroads, VA:** *Virginia's first DDI*

In addition, Corman Kokosing has significant experience within the I-95 corridor within downtown Richmond rehabilitating several bridges including:

- **Chamberlayne Avenue over I-95:** Bridge Deck Replacement
- **Belvidere Street over I-95/I-64:** ABC Bridge Deck Overlay and Structural Steel & Concrete Repairs
- **Hermitage Road over I-95:** Bridge Deck Replacement and Substructure Repairs
- **7th Street over I-95:** Bridge Deck Replacement

These projects include some of the same activities required for this project such as utility protection and relocation, accelerated bridge construction techniques, and complex maintenance of traffic issues, all in the same corridor as this project.

Throughout the years, Corman Kokosing has built a solid reputation of strategically aligning with experienced Design-Build partners who will be a technical asset as the sole responsible engineer. For this project, we have partnered with **Whitman, Requardt & Associates, LLP (WRA)** as the Lead Designer, collectively referred to as the “Corman Kokosing/WRA Team”. WRA has been specifically chosen, along with **Jeremy Schlussel, PE** as the Design Manager (DM), because they have proven they are the leading engineering firm for Design-Build projects. They have designed and detailed over 30 superstructure replacements over the past 15 years and their extensive knowledge of working with and within the City of Richmond will provide the design expertise to make this a successful project. WRA and Corman Kokosing have experience teaming on successful Design-Build projects:

- **Fall Hill over I-95:** Staged Bridge Replacement as part of the Fall Hill Avenue Widening and Mary Washington Boulevard Extension
- **Berkmar Drive over Rivanna River:** New 716 ft. bridge as part of the Route 29 Design Solutions
- **I-64 over Chickahominy River:** Bridge widening, deck replacement, partial superstructure replacement and sub-structure repairs as part of the I-64 Widening from Exit 200-205

In addition to the Design-Build experience, Corman Kokosing has successfully completed over 25 projects in the Richmond District that WRA has designed with an estimated construction value of over \$65M. Example projects located in the I-95/I-64 Corridor through Downtown Richmond include:

- **I-64 over Shockoe Valley:** ABC Deck Rehabilitation
- **I-64 over Shockoe Creek:** ABC Deck Rehabilitation, Structural Steel and Substructure Rehabilitation
- **5th Street and 7th Street over Leigh Street:** ABC superstructure replacements for 2 bridges for the City of Richmond DPW; the two projects were completed in less than eight months
- **Belvidere Street over I-95/I-64:** ABC Deck Rehabilitation and Substructure Rehabilitation
- **Route 360 (Mechanicsville Turnpike) over I-64:** Major Bridge Rehabilitation
- **I-95 over James River, CSXT and Main Street:** Fracture Critical Structural Steel Rehabilitation

All nine of the projects listed above were designed by WRA and built by Corman Kokosing with the same proposed personnel for this project.

In addition to Jeremy’s VDOT project history, he brings the unique experience of having served as the Acting City of Richmond Bridge Design Manager on two occasions while the City was in the process of hiring for this critical position. This history of directly working with the City’s DPW and Staff will provide our team with unmatched knowledge of their operations and the ability to shepherd the work through their system as a major stakeholder for this critical project.

To assist our design efforts, we have included the firm of **Athavale, Lystad & Associates, Inc. (ALA)** on our team. WRA has teamed with ALA on projects similar in Virginia and Maryland for the past 20 years. ALA has worked with Corman Kokosing on Design-Build Projects such as:

- **Route 1 (NB & SB) Accotink Creek:** Staged Bridge Replacement, Fairfax County, VA, FHWA
- **Ramp C over Route 13 Business:** Staged Superstructure Replacement & Bridge Rehabilitation, Wicomico County, MD, MDSHA

3.3.1 Key Personnel

The Corman Kokosing/WRA Team has assembled highly qualified and experienced individuals and structured them for optimal performance. Our proposed key personnel were chosen based on experience with performing design and construction within a complex urban setting, including high traffic volumes, coordinating multi-modal transportation, and proximity to critical entities and infrastructure. These individuals share a history of successful projects and established working relationships that serve well in this context. They were also selected based upon their availability to staff the project. Their proven strengths will minimize VDOT’s risks and staffing requirements. Although our task leaders and technical staff are responsible for individual assignments, such as design, public involvement, and/or construction, everyone is responsible for project success! The table below introduces our Key Personnel with resumes in the Appendix:

.1 Design-Build Project Manager (DBPM)	Ryan Gorman, PE, DBIA – Corman Kokosing
.2 Quality Assurance Manager (QAM)	Mike Saunders, PE, CCM, DBIA – NXL
.3 Design Manager (DM)	Jeremy Schlussel, PE – WRA
.4 Construction Manager (CM)	John “Jake” Leffler – Corman Kokosing
.5 Lead Utility Coordination Manager	Paul Martin – WRA

Value-Added Staff: The Corman Kokosing/WRA Team also includes the following value-added staff to deliver a quality product on time and on budget:

- **Deputy Design-Build Project Manager (DDBPM) Chris Rutkai, PE (Corman Kokosing)** will be assisting the DBPM in allocating resources across the multiple project locations. Chris’ role within Corman Kokosing as the Central Virginia Regional Operations Manager, has given him experience with the local labor market, an understanding of the local disadvantage business network, and established working relationships within the VDOT Richmond District. These experiences will benefit the project as it provides the DBPM an additional resource to effectively manage the project; while at the same time providing additional support for the Construction Manager. Chris’ experience and working relationships have developed over the years working within the VDOT Richmond District on many bridge rehabilitation and on-call contracts. For this project, Chris will report directly to the DBPM and will serve the team with his value-added knowledge of the District and local working conditions.
- **Design/Construction Integrator (DCI) Kyle LaClair, PE (Corman Kokosing)** will coordinate the construction and designer staff, which will benefit VDOT by ensuring the team is working in unison towards delivering a quality project that meets VDOT’s requirements. Kyle has been involved with Design-Build projects since 2002 and has 21 years of highway and bridge design and construction experience. His previous roles as a design manager and project manager give him the credentials to serve in this role effectively. Kyle has vast technical experience within traffic, water resource, and highway engineering, coupled with extensive project management experience. For this project, he will serve under the DBPM in collaborating, reviewing,

and coordinating the technical aspects of the project as it relates to contract conformance, constructability, and schedule adherence. In addition, he has past experience managing Design-Build bridge projects as a Design Manager that will serve as an additional resource and insight for this project. Kyle’s multi-faceted expertise will be a key instrument available at the DBPM’s disposal.

- **Utility Engineer/City DPU Liaison: Dan Seli, PE (WRA)** has over 33 years of related experience with VDOT and the City of Richmond DPU and will serve as the liaison for all utilities that could impact City services. He has worked for over 29 years on the Annual City DPU Engineering Services Contract and has routine meetings with the City for all utility projects that are ongoing within the City. Dan brings to the team a unique understanding of the City's operations, policies, and procedures, which will assist the Corman Kokosing/WRA Team in navigating complexities of maintaining the City utilities as part of this project. As an example of this, he was responsible for the complex utility coordination for the two superstructure replacements on 5th Street and 7th Street over Leigh Street to maintain services during these projects where Corman Kokosing was the General Contractor. Dan will report directly to the DM.
- **MOT Engineer/City DPW Liaison: Mark Vasco, PE (WRA)** has over 35 years of experience and will serve as the liaison for any MOT resultant impacts to the City of Richmond’s streets and roadways. He has coordinated with the City and has worked with them for over 20 years via the DPW Annual Engineering Services on-call contract. Within this position, he interacts on a regular basis with City DPW staff and various other departments for reviews (including the City Planning Commission) of ongoing City projects and is thoroughly knowledgeable of what is required to work on city streets; this effort includes obtaining the necessary Work-in-Street Permits for all projects taking place within the City of Richmond streets and roadways. Similar to Dan, an example of Mark’s efforts includes leading the efforts for the MOT/detours necessary for the superstructure replacements on 5th Street and 7th Street to coordinate with VDOT, FHWA, and the various City Departments impacted by the roadway closures for this project. Mark will report directly to the DM.
- **Traffic/Signals Engineer: Dana Trone, PE, PTOE (WRA)** has 25 years of experience in traffic engineering and analysis, including the development of TMPs for numerous complex interstate and DB projects, including the I-95 Safety Improvements at Route 3 and the Fall Hill Avenue Widening projects. Within the Richmond District, Dana led the development of the TMPs for the I-64 over Shockoe Creek and BBRR, I-64 over Shockoe Valley, I-95 over James River, Route 360 over I-64, and I-295 over James River bridge maintenance and repair projects, as well as the recently designed I-95 over Reymet Road project. For each project, Dana evaluated maintenance of traffic scenarios, including full closures, and temporary lane closures (e.g., off-peak, full-time, or night-time) to determine the impact on the traveling public. Multiple alternatives were considered to establish a range of potential queues and delays and to identify the most practical alternative to minimize impacts to the traveling public while providing sufficient work area and duration to conduct the bridge construction activities. For the I-95 Fredericksburg Major Projects, she is currently monitoring traffic operations and safety using readily available RITIS and crash data to determine whether mitigation measures should be considered to reduce the potential for delay and incidents. Dana will report directly to the DM.
- **MOT Superintendent: James Waters (Corman Kokosing)** will leverage his 20⁺ years of experience managing and implementing traffic control and establishing work zones within the central Virginia area including the I-95 corridor in Downtown Richmond. James has performed traffic control operations for several bridge rehabilitation projects including: Chamberlayne Avenue over I-95 Bridge Deck Replacement, Belvidere Street over I-95/I-64 Bridge Repairs, Hermitage Road over I-95 Deck Replacement and Substructure Repairs, and 7th Street over I-95 Bridge Deck Replacement. He has a current VDOT Intermediate Work Zone Traffic Control certification, which coupled with his vast local experience and knowledge makes him a value-added person to this project as he understands what works and what does not work within this corridor. He will have a direct communication connection with the MOT Engineer, as well as report directly to the CM.

3.3.2 Organizational Chart

Our organizational chart on Page 6 illustrates our *chain of command* of all companies and notes our proposed key personnel. Solid lines identify the reporting relationships of our team members in managing, designing, and constructing the project and illustrate clear reporting lines from the DBPM to the design and construction teams. Dashed lines represent indirect reporting/communication and obligations to the owner and/or corporate

management. Our chart also shows that a clear separation and independence exists between quality assurance (QA) and construction, with no contractual relationship and no involvement in construction operation.

Functional Relationships – Integrate to Facilitate: Design-Build unites the contractor and designer more than just contractually. It integrates innovative design and construction techniques that benefit schedule and cost, which lead to client satisfaction. Since the DBPM sets the vision for this integrated approach, he must have the credentials/experience to oversee, not only the construction, but the design and engineering aspects as well. This key person must also have a proven record of successfully completing projects with this integrated approach. Through our DBPM and relationships with the other key personnel, we will create a foundation that will interact/partner with VDOT and third-party stakeholders. Additional ways we will be fully-integrated include:

- Inter-disciplinary design reviews prior to milestones to ensure design disciplines are coordinated.
- Corman Kokosing constructability reviews of design, especially for Maintenance of Traffic (MOT), Utility Protection and Relocation Plans, and Bridge Rehabilitation Phasing Plans to serve as an example.
- Weekly schedule meetings to review the previous week’s work and develop the three-week look ahead, and monthly scheduling meetings to review CPM progress during design development and construction.
- Weekly foreman meetings to discuss the schedule, safety and coordination.
- Morning Action Plan (MAP) meetings with the crews to set the safety and production goals for the day.
- Weekly progress meetings with VDOT to review and discuss quality, submittals, and progress payments once construction begins.
- Periodic partnering meetings with all stakeholders for issue resolution.

Design-Build Project Manager (DBPM) Ryan Gorman, PE, DBIA (Corman Kokosing) will be responsible for design/construction, quality management, safety and environmental compliance, contract administration, and all other services, including procuring/furnishing materials, equipment, services, and labor per the contract. He will attend monthly progress meetings and be available to VDOT. Ryan has the expertise/experience to supervise/exercise control of the work and accepts responsibility for the final work product. *He will be VDOT’s primary point of contact and will Coordinate, Integrate, and Administrate the*

All five key personnel worked together on the successful I-64 Widening Exit 200-205 Design-Build, Richmond District

Corman Kokosing/WRA Team, including design, construction, quality assurance, MOT, safety, and utilities. Ryan will be responsible for meeting our contract obligations and avoiding/resolving disputes per the RFP. He will supervise the DM, LUCM, DCI, CM, ROW Manager, QAM, *and manage/coordinate public outreach/meetings with assistance from our Public Outreach Coordinator.* Ryan will be involved with preconstruction, design, construction, and punch out and will answer questions from stakeholders, citizens, elected officials, etc. He will assist with constructability reviews, safety audits, and oversee the quality management program, purchasing, and construction.

Quality Assurance Manager (QAM) Mike Saunders, PE, CCM, DBIA (NXL) will report to the DBPM and have direct, independent access to VDOT. He will ensure work is performed in conformance with contract requirements, *Minimum Requirements for QA and QC on Design-Build and Public-Private Transportation Act Projects*, approved designs, and *approved for construction* plans/specifications. Mike will be responsible for development/adherence to the QA Plan, QA inspection and testing of all materials used and work performed. As an independent entity, he will audit and monitor Corman Kokosing’s Construction QC Program. Mike can stop construction, enforce specification compliance, and issue/require resolution of Non-Conformance Reports (NCRs). He will manage the QA program, including the QA inspectors and independent QA testing firm and testing technicians. The QA team will conduct independent and concurrent tests and analysis of the work with the construction QC team. Mike will maintain project quality records and approve/submit pay estimates. He will submit monthly written reports to the VDOT Project Manager and our DBPM assuring oversight of our Quality Program. Quality Assurance will be coordinated with, but independent of, daily QC and construction. Mike will be given timely notice of construction activities so his QA staff can be on-site to document compliance. He will have access to meetings and records he needs to provide independent assurance that construction complies with contractual and design requirements. Mike will have unrestricted access to the construction and fabricator sites/facilities.

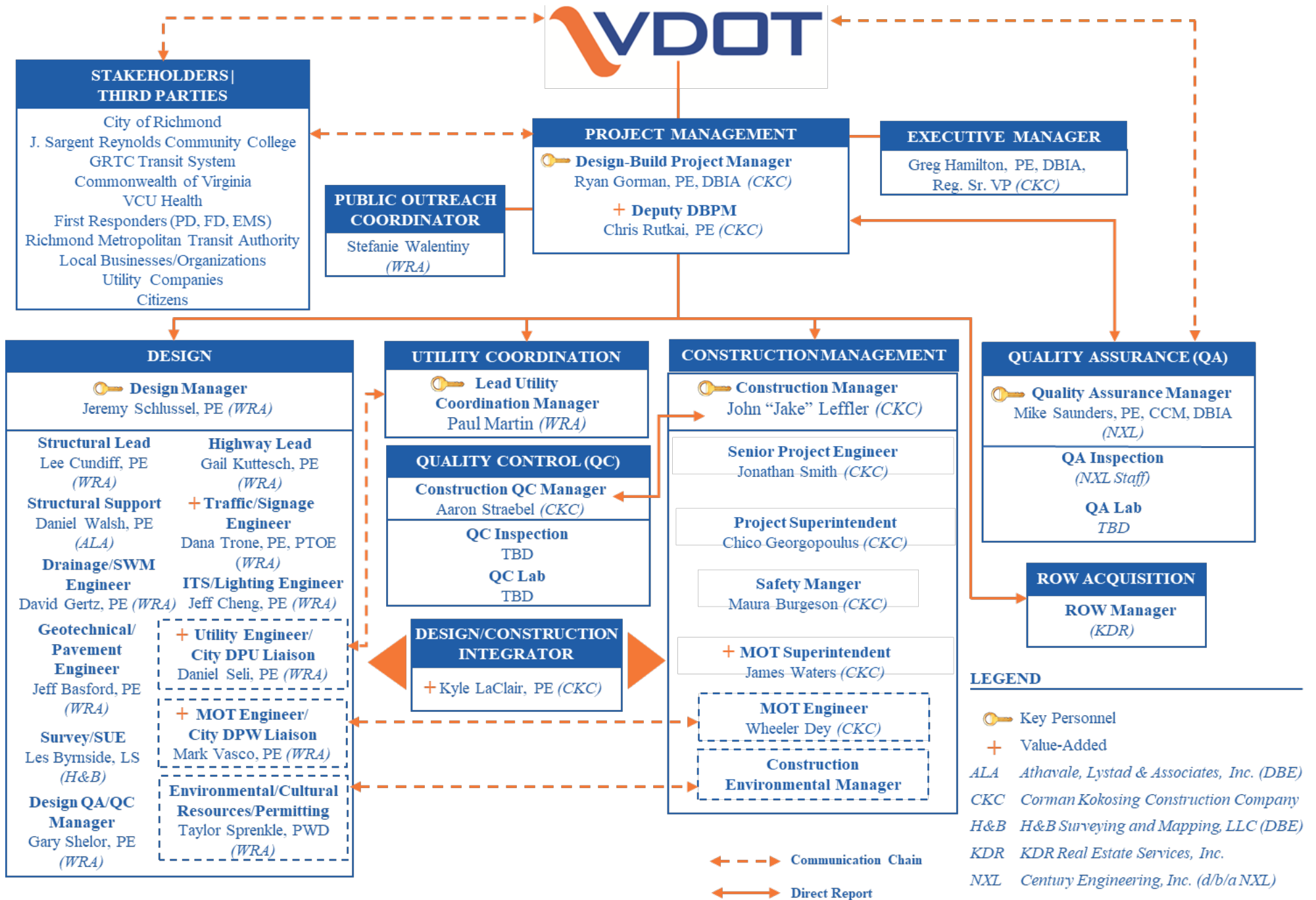

Design Manager (DM) Jeremy Schluskel, PE (WRA) will report to the DBPM and provide a quality engineered product, meet design milestones, continually coordinate with the Corman Kokosing/WRA Team and ensure Design QA/QC Manager and independent reviewers are not tasked with other project responsibilities. Jeremy has been Design Manager on seven On-Call S&B Contracts since 2006 and served as the Lead Bridge Design Manager for the City of Richmond On-Call Contract, where he has been the EOR for over 30 superstructure replacement projects similar to these five superstructure replacements. In addition, he has been the DM for the multiple bridge replacement projects and was the overall Design Manager for the for the Denbigh Blvd. (Route 173) over I-64 and CSXT Staged Bridge Replacement project in the City of Newport News that Corman Kokosing is under contract to VDOT to build. He is known to provide high quality plans with innovative solutions for long-term low maintenance solutions on all projects. Jeremy will develop/oversee our rigorous internal QA/QC program to ensure all design work is performed per contract and current VDOT policies, procedures and guidelines and includes interdisciplinary/safety/environmental/constructability reviews of each design package. He will manage all design elements, including roadway, structural, traffic, drainage, permitting, including permits required by the City of Richmond, geotechnical, utility, surveying, MOT, ROW, and environmental. Jeremy will allocate/assign resources, oversee design subcontractors, including bridge design, survey (including subsurface utility), geotechnical drilling (if necessary) and material testing (as needed), coordinate design and review schedules, develop/implement any corrective measures to maintain schedule, and integrate environmental compliance measures into the design. He will coordinate design and construction with each discipline lead to achieve design and schedule goals and remain involved once construction starts to oversee any plan modifications, ensure field changes/modifications meet approved design(s), revisions are documented in as-built plans, respond to RFIs, review shop drawings, and review construction/MOT activities with the CM as work progresses for any opportunities or changes that need to be made. Jeremy will coordinate with all of the discipline design leads and will coordinate all activities with the DBPM, DCI, and LUCM.

Construction Manager (CM) John “Jake” Leffler (Corman Kokosing) has 16 years of the hands-on experience it takes to manage construction, including QC activities and ensure materials and work meet contract requirements and *approved for construction* plans/specifications. For the past eight years, he was worked exclusively on design-build projects in the Commonwealth of Virginia, holding the titles of Construction Manager, Quality Control Manager, and Design Integrator. He will manage the on-site construction team comprised of project controls, construction QC manager, superintendents, and project field staff, including scheduling, safety, environmental compliance, utilities and MOT. ***Jake will only be assigned to this project and will be on-site full-time throughout construction.*** He will play a key role in conjunction with the DCI, Kyle LaClair, and design QA/QC Manager in design constructability reviews, and work with DCI to coordinate between the design/construction forces with regard to utility protection and relocation, MOT, and accelerated bridge construction plans. He will focus on ensuring construction is performed safely, and along with our construction QC manager, that materials and work are per approved plans/contract documents. Jake will coordinate with the DM during construction for accurate/timely issuance and review of RFI/shop drawings, field visits, preparation of as-builts and plan revisions. Jake reports to the DBPM.

Lead Utility Coordination Manager (LUCM) Paul Martin (WRA) has 33 years of experience delivering major transportation projects, including 15 years specializing in utility coordination for VDOT and municipalities in Virginia. Paul is WRA’s DB lead for utility relocation and coordination and has managed utility work on similar projects, including the I-95 Safety Improvements at Route 3 DB, the I-95 Express Lanes STE DB, and the I-64 Widening DB Exit 200 to 205 with Corman Kokosing. Paul will oversee the utility coordination process, including the initial collection of as-built drawings from the utility companies, analyzing conflicts, hosting the utility field inspection, developing a utility relocation plan, preparing estimates, coordinating utility relocation schedules, overseeing utility coordination document control, processing of utility relocation invoices, and ensuring land use permits are obtained. Paul will report to the DBPM and will interact closely with the DM and CM.



In review of the project, the Corman Kokosing/WRA Team has identified three key areas that will be critical in the success of this project. These include a well-managed project, a safe and mobile project, and an efficient implementation plan that includes accelerated bridge construction techniques. These three key areas are all interrelated.

A Well-Managed Project. Keys to success are communication and coordination between the Corman Kokosing/WRA Team, VDOT, review agencies, and stakeholders, which is a hallmark benefit of the design-build process. This is based upon open/honest communication, frequent meetings and updates. We will conduct internal weekly meetings during design with key construction/design staff. Tracking sheets monitor progress of utility relocations/coordination and design disciplines, as well as design approvals. Once construction starts, design participants stay involved. Added to the weekly meetings as construction starts are superintendents, field surveyors, the MOT Manager and the Construction QC Manager. Key stakeholder representatives, including VDOT, and other interagency stakeholders, will be invited. Monthly meetings will be held with the Corman Kokosing/WRA Team, VDOT, QAM, and stakeholders to enhance partnering and resolve issues quickly.

A Safe and Mobile Project. This aspect is a key element for success as it relates directly to the everyday lives of the traveling public. The Corman Kokosing/WRA Team understands that minimizing delays that affect the traveling public will result in a safer and more mobile public. This will directly affect the overall success of the project, especially considering the volume of traffic and number of work zones through the corridor.

An Efficient Implementation Plan. The implementation plan starts at design with the engineer’s working directly with the builder to embrace the accelerated bridge construction (ABC) mindset. The use of pre-fabricated materials, including pre-cast decking, will need to be well thought out as it relates to phasing and the conflicts with bridge mounted utilities. Staging and equipment set up will play a crucial role in determining timely completion of each step of the project and determining the level of impact to the traveling public.

3.4 TEAM EXPERIENCE

The Corman Kokosing/WRA team has reviewed our past projects that best demonstrates previous experience and the following is a summary:

Project Name	ABC Construction	Urban Corridor	Limiting Impacts	Innovative Bridge Designs	Utility Coordination
Corman Kokosing Projects					
Route 29 Solutions: Rio Road	✓	✓	✓	✓	✓
Route 1: WWB Urban Deck	✓	✓	✓	✓	✓
US 13/50: Rehab. Bridges	✓	✓	✓	✓	✓
WRA Projects					
Route 7 over Route 267	✓	✓	✓	✓	✓
Denbigh Blvd. (Route 173) over I-64 and CSXT	✓	✓	✓	✓	✓
I-95 over Route 608 (Reymet Road)	✓	✓	✓	✓	✓

For further details about each project, please see our Work History forms for Corman Kokosing (Attachment 3.4.1 (a): Lead Contractor) and for WRA (Attachment 3.4.1(b) located in the Appendices section.

3.5 PROJECT RISKS

The Corman Kokosing/WRA Team will employ the Construction Management Association of American (CMAA) endorsed approach to risk management through a *Risk Register*, which includes a list of identified risks, potential impacts, and mitigation for each. A robust risk management plan considers risks throughout the project’s life and delivery processes. Our team’s risk management plan has already jumped into action, will evolve throughout design and construction, and position us to respond to changes as specific issues unfold. We employ a five-step Risk Management Plan:



- 1. Identify:** Name risks, determine cause and effect, and categorize

2. **Assess:** Assign probability of occurrence, severity of impact, and determine response
3. **Analyze:** Quantify severity, determine exposure, establish tolerance level, and determine contingency (applicable during preliminary design and pricing)
4. **Manage:** Define response plans and actions, establish risk ownership, and manage response (after NTP)
5. **Monitor/Review:** Monitor/review/update risks, monitor response plans, update exposure, analyze trends, and produce reports (after NTP, during design, during construction)

We have reviewed the available information, visited/documentated the site, and collectively discussed potential critical risks. Critical risk items were identified based on the following criteria:

- Impact to the traveling public (including through travelers, commuters, public transit, pedestrian, and bicycle users).
- Potential influence to the overall project schedule and milestones.
- The likeliness of discovering unknown conditions associated with the rehabilitation of the bridges.

These unique risks were identified based on the criteria listed above, which we consider relevant and critical to the success of the project.

RISK NO. 1 | MAINTENANCE OF TRAFFIC DURING CONSTRUCTION

The I-95 corridor through Downtown Richmond includes a confluence of several major arteries to and from the City of Richmond and serves as a major junction point for the Route 195 Downtown Expressway and I-64. The annual average daily traffic (AADT) estimates within the I-95 corridor is 149,000 vehicles per day. With the high volume of traffic combined with the horizontal, vertical, and bifurcated roadway on I-95 and the City Street Network, the ones between MP 74.94 to 75.35 & 75.77 to 75.92 for I-95 NB, MP 74.90 to 75.07 for I-95 SB, and 14th Street south of Broad Street (Detour Route for weekend closures) have all been identified by VDOT as high crash locations and Potential Safety Improvement (PSI) segments for 2018, a rating used by VDOT to identify locations where VDOT should consider an engineering review for possible mitigating countermeasures. This is due to the mix of commercial and personal vehicles and users which include local commuters, through travelers, and a mix of heavy industrial and commercial traffic. In addition, the major cross streets served by the bridges to be rehabilitated include a diverse mix of users including public transportation (GRTC), pedestrians, and bicyclists in addition to the normal vehicular traffic.

Why Critical: This segment of I-95 is a critical part of the overall transportation network within the region that affects thousands of users every day. This corridor is essential to business and regional commerce, with the local network of streets that convey traffic to major employment hubs and healthcare facilities within the City of Richmond. Maintaining the traffic during construction will be essential to ensuring the uninterrupted and free flow of the traveling public on both I-95 and the cross-over street network. The free flow of traffic has a direct impact on the traveling public affecting the quality of life and essential business that depend on timely movement of people and products through this corridor.

Impact: The rehabilitation of the five bridges will include various phases of construction requiring the need for significant changes to normal traffic patterns along all the cross-over streets. Lane closures, lane shifts, and closed facilities will greatly affect traffic operations, increase travel times, and impact the traveling public and the timely movement of people and commerce within the region. Traffic congestion and abrupt traffic pattern changes can lead to traffic incidents that can further degrade traffic operations and safety. More significant is the potential impacts to I-95 and other major arterial roadway networks. The I-95 corridor has a history of recurring peak period congestion and queues that spill over to other major highway facilities (i.e., I-64, Downtown Expressway, and/or City Streets). In addition, the quality of life will be impacted for the various residential communities that gain access to the City of Richmond Downtown area due to congestion along the cross-over streets and back-ups on I-95 due to construction. Tourist, business, and residential destinations will be greatly affected by changing traffic patterns. Furthermore, specific communities and destinations that will be influenced by the traffic patterns include the Capitol complex, VCU/VCU Health, the Riverfront, Shockoe Slip, Shockoe Bottom, and many other destinations. Again, these impacts are the net result of the altered traffic patterns that have an effect on the regional highway network.

Our Team has reviewed the potential MOT as provided in the RFQ documents and the following elements are noted as impacts:

- **Pedestrian Movements:** Maintaining access for pedestrians and bicycles will be a significant concern for the City of Richmond. Adequate ADA accommodations will need to be maintained throughout construction along designated routes for each stage of construction. Access will also be needed to be maintained along and throughout the duration of all detours.
- **Turning Radii:** The detour routes will require a thorough review of all turning radii to ensure large trucks and buses can be accommodated for various stages. For example, one such location is the intersection of 1st Street at Charity Street, where the existing conditions will prohibit large turning radii for larger vehicles and 7th Street over I-95, which is the exit from I-64 WB to I-95 SB.
- **Utilities:** Depending upon the final sequencing related to existing utilities to be relocated, all detours/MOT set-ups will impact the roadways ahead of the actual bridge construction or simultaneously, which will require coordination among Contractors.
- **Interstate Ramps:** With the confluence of I-95 and I-64 and the ramps for these roadways being located in the work zone, there will be impacts during nighttime crossovers along I-95. These movements will require coordination and planning, which may take the routes onto City Streets.
- **GRTC:** With the closures and or detours for the various bridges, GRTC bus stops and routes will require a thorough review and a plan for maintaining transit services throughout construction. This will be critical for the 1st Street, 5th Street, and Broad Street bridges; in addition, while the Pulse does not cross over I-95, the proposed detour will impact the traffic patterns and may delay its service.
- **Stormwater Facilities:** With the proposed work on both City Streets and I-95, and with the proposed crossovers, there will be locations that existing storm drains will be impacted. Our Team will have to evaluate to ensure the proposed activities do not cause a situation that will create an unsafe travel-way during a storm event.
- **Construction Laydown:** With the bridges all being located on City Streets, the laydown locations for each project will be critical to minimize the impacts to local traffic. This is especially critical for demolition activities and delivery activities, such as removal/setting of structural steel where significant construction activities will impact the public.

Mitigation: To address these risks will take significant planning internally and with external partners to ensure that the vehicular and pedestrian traffic has a clear and safe understanding of moving through a very urban work zone. The Corman Kokosing Team will mitigate the risks associated with maintaining traffic through this urban work zone(s) through the development of a Type C TMP including a detailed Temporary Traffic Control Plan, a Public Communications Plan, and Transportation Operations Plan.

- **Work Zone Traffic Impact Assessment:** The construction phasing plan will be developed and analyzed by our traffic engineers to ensure that proposed impacts to traffic operations are minimized during each phase of construction. A Work Zone Traffic Impact Assessment (WZTIA) will be prepared to ensure the development of successful staging and MOT plans. The study will evaluate the impacts on the City Streets, adjacent intersections as well as impacts to operations along I-95. This is similar to work WRA completed on Route 360 over I-64, where the staging impacted the on/off ramps to I-64 and local roads in both Henrico County and the City of Richmond.
- **Maintenance of Traffic Plan:** A detailed Maintenance of Traffic (MOT) plan that anticipates all aspects of the bridge rehabilitation for each bridge will include the construction phasing, staging requirements, roadway approach construction, utility relocation and in-place support, temporary drainage, phased E&S, temporary SWM, signalization, lighting, and ITS elements. This will also include placements and designs of traffic control devices such as Traffic Barrier Service, Group 2 Devices (Barrels), temporary construction signing and markings, temporary pavement, impact attenuators, TTC applications, temporary signals, Type III Barricades, Electronic Arrow Boards, and changeable message signs (PCMS). The MOT plan will also incorporate the following elements:

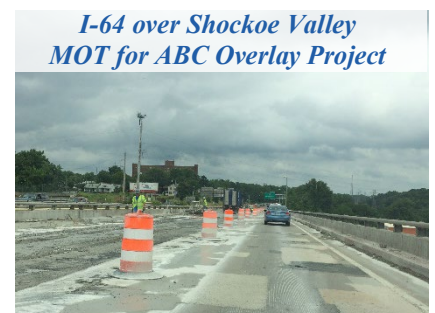

- Proactive scheduling and coordination between the varying bridge rehabilitation projects within the corridor. For example, the 4th Street bridge is to be utilized during the detouring required for the 7th Street bridge construction; therefore, it is essential that accurate scheduling and coordination is conducted for subsequent construction of these two bridges and contingency plans are always ready if required for an unforeseen situation.
- The MOT staging and detour setup will be inspected daily to ensure that all traffic control devices are properly placed, aligned as intended, and maintained thoroughly to enable visibility at all times during construction, non-working hours, and designated detour times.
- Strategically placed laydown locations will be identified early in the process and utilized as to not impact the flow of traffic through the work zones, detours, or any other City streets or roadways.
- Expeditious construction and inclusion of accelerated bridge construction (ABC) techniques will be essential for minimizing the duration of temporary detours.
- Proper and advanced communication and meetings to coordinate the utility relocation efforts will aid in mitigating impacts.
- **Traffic Operations and Incident Management Plan:** A Traffic Operations plan will include a detailed Incident Management Plan to establish an operating protocol for responding to any incidents within the staged work zone corridors or detours. Clearing incidents safely and quickly depends on a coordinated, multi-agency approach supported by integrated communications. The Incident Management Plan will be developed based on our extensive knowledge of the I-95 corridor and surrounding City roadway network and our thorough understanding of the available alternate routes. The Incident Management Plan will provide proactive measures to identify and locate incidents rapidly, quickly respond to them, clear the incidents, and implement preplanned detours in the event of a major incident. The Incident Management Plan will leverage existing ITS elements that VDOT has implemented along the I-95 corridor including the Safety Service Patrol, CCTV cameras, dynamic message signs (DMS), as well as signal communications along the City of Richmond roadway network. Detour signage will be placed as needed in accordance with the incident plans and uncovered when an incident occurs that will direct traffic accordingly. This is similar to what Corman Kokosing prepared for the ABC overlay for both I-64 over Shockoe Creek and I-64 over Shockoe Valley.
- **Communication Plan:** In addition to establishing a detailed Communications Plan that will be implemented throughout the life of the project, our Team will conduct additional risk mitigation strategies to further educate the public about the anticipated impacts to traffic operations during construction. Following contract award, we will hold an initial partnering meeting with VDOT, the City of Richmond traffic engineering staff and other key stakeholders to review the project requirements and discuss traffic issues related to construction. From this initial meeting, we will develop a checklist of responsibilities and timelines for achieving activities and goals for a successful TMP including public outreach. Additional public outreach activities will include:
 - Informational meetings to inform the public of project activities and solicit project feedback to incorporate into our TMP.
 - Pardon Our Dust meetings to inform the public of construction activities.
 - Establishing a formal public communications plan to maintain regular communications with the public and stakeholders including social media strategies to reach the largest number of potentially impacted travelers. This type of action plan was critical to the success of WRA’s I-64 over Shockoe Creek and I-64 over Shockoe Valley ABC Deck Overlay Projects.
 - Work with first responders to obtain their input on our TMP and subsequently notify their offices of changes in patterns to not affect their operations.

Role of VDOT and other Agencies:

VDOT’s role will be the standard review of the TMP and communication plans as part of the project plans and their use of the TOC, LCAMS, etc. systems to notify the public and coordination of construction activities within the corridor.

RISK NO. 2 | UTILITY CONFLICTS AND RELOCATIONS

With all five bridges having multiple utility facilities from multiple providers attached to the superstructures, there is a considerable risk to the project schedule and costs coordinating the retention, replacement, or relocation of these facilities while reconstructing the bridge superstructures and maintaining project schedules and budgets. Additionally, there will be added complications to this process as these utility facilities are providing critical services to the surrounding community, which must be maintained. These bridges are in close proximity to each other so the sequencing of the project work will need to be done in such a way that the continuity of these services are maintained as many of the facilities may be the very ones that provide the additional capacity needed to be used when others are temporarily taken out of service. A significant risk is synchronizing the utility owners' relocation schedule with the bridge construction schedule. Our relationships with the utility owners on this project will assist with meeting the utility owners' schedules.

Why Critical: There are a wide variety of existing utility facilities attached to the bridges. These provide water, gas, sewer, power, and communications services to the surrounding community that cannot be disrupted without affecting public health and safety and thus will not be permitted to be taken out of service unless alternative sources are available to supply them. The bridge projects will hold a lesser importance than these services so its work will need to be scheduled and sequenced in such a way that they are maintained. The owners of these facilities are a combination of approximately 13 public and private providers and they are not accustomed to having to abide by the schedule of others when performing work on their facilities. Thus, it will be the responsibility of the design-builder to coordinate with them in an effective and efficient manner to provide them the needed information to be able to make the necessary changes on those facilities and to fit their schedules for work into the overall bridge project schedule and the schedule of the other utility providers. The scheduling and sequencing will also need to be dynamic and flexible as a wide range of situations beyond the control of the design-builder can disrupt the schedules of the utilities. The majority of the conduits located on the bridges are transite asbestos material, which will need special care in removal and are an added risk. Only through the timely completion of the utility work will the bridge project proceed to completion.

Impact: The primary impacts from the utility accommodations will be on the project schedule, costs, and safety.

- **Completion Schedule:** The project's current completion date allows for a total project length of 38 months from project award to project completion. As it is currently not known how the utilities will need to sequence their work to be able to maintain their services, it is possible that this is not a sufficient amount of time. Additionally, things beyond the control of the project such as natural or manmade disasters, labor issues, or material supply issues could occur, which would affect the ability of the utilities to work on this project. It adds much uncertainty to the project.
- **Project Cost:** By Virginia code, all utility costs for relocations or protections on a project involving an Interstate Highway and within City limits is a project cost. Thus, all the utility costs for the project will need to be estimated in advance and included in the project's lump sum bid. The uncertainty of the utility work will require a delicate balance between contingency funding to cover these costs and the ability to remain competitive to win the project.
- **Safety:** Electricity, natural gas, and high-pressure water all have the ability to cause damage and injury by their very nature. The design-builder will need to take all proper precautions and use appropriate safety measures when working around these facilities in order to keep their crews and the general public safe.

Mitigation:

- **Design Mitigation Strategy:** A full understanding of all the existing facilities and which ones will need to be maintained, abandoned, relocated or betterment improvements provided will provide the project design team the information to accommodate the utilities. There will also need to be a full understanding of the procedures that the utilities will need to take in order to switch over their facilities from existing locations to new ones. In depth discussions will be held with the utility representatives early in the design process which will provide the design team specific details on the existing facilities, specific utility relocation requirements, allowable shutdowns and if the utility wants to incorporate any betterments into the project. This information will assist the design team in identifying the critical aspects of the utility relocations and

how the relocations can be incorporated into the new bridge superstructures. All aspects of reducing impacts to the existing utilities including temporary support of utilities, relocation options including directional drilling and the ability to temporarily shutdown the utilities during certain phases of construction will be evaluated and discussed with the utility owners. WRA’s relationships with the utility owners involved on this project will assist the team in coordinating, getting approval and relocation accomplish without impacts to the overall project schedule.

- Construction Mitigation Strategy:** Strategic project phasing of the bridge improvements and temporarily supporting utilities during construction can remove the need to relocate utilities, reduce the schedule impacts and reduce the risk associated with the utility relocations. Goal number one will be to support the existing utilities in place during the superstructure replacements when possible rather than relocating them. Corman has successfully done this on many of the aforementioned bridges in this corridor as well as other projects throughout the Commonwealth. Typical support details will include a carrier beam on the underside of the utility that is supported from the existing substructure to remain or from shoring towers outside of the I-95 travel way. When it is not possible to support the utility in place, attempts will be made to phase the bridge replacement such that the new utility is installed on the first phase of the bridge replacement while the existing utility remains in operation on the existing bridge to be replaced in a future phase. Lastly if a relocation is required, efforts will be made to assist the utilities in the performance of their work. This can range from providing traffic control services and laydown areas for them to ensuring that no crews are scheduled to be working in the same areas at once and interfering with each other. Surveying and inspection activities will also take place to ensure that utility relocations are performed in accordance with approved plans and will not cause any further conflicts.



Role of VDOT and other Agencies:

VDOT and other agencies will play significant roles in the review and approval of utility relocation plan and estimates and the approval of any necessary environmental or municipal permits required by the utilities in order to perform their work.

RISK NO. 3 | SUBSTRUCTURE CAPACITIES OF EXISTING ELEMENTS

As part of the Richmond Bridge Rehabilitation Bundle for the five bridges over I-95 in the City of Richmond, the goal is to rehabilitate the substructure elements to increase their service life to accommodate the new superstructures through pier seat/abutment modifications, concrete repairs, including corrosion mitigation, and/or pier cap removal and reconstruction. With these elements being completed in the late 1950s as part of the Richmond-Petersburg Turnpike, many have had work performed in the past, they have exceeded their original 50-year design life, and they have been exposed to significant environmental conditions which have caused material deterioration. The substructure capacities are critical for a successful project and there is risk associated with these elements from not only their material condition and loading capacities, but from within the RFQ itself with conflicts of wording where one statement says, “minor substructure repairs will be performed on these structures” but another statement says, “Pier Cap removal and reconstruction”. These two RFQ statements along with their material and loading capacities present a risk to our Team as part of this project.

Why Critical: Having worked on many bridge structures along this corridor that were built with the original Richmond-Petersburg Turnpike in the late 1950s and throughout Downtown Richmond, we have learned that no two of the bridges were designed and detailed the same and that the material conditions vary greatly due to their exposure to over 60 years of roadway salts. With this variability in their general condition ratings and the that the substructure and foundations elements designed in the 1950s (and with Broad Street over I-95 having already had a major rehabilitation/lengthening in the 1970s) the substructures may not support the revised AASHTO temporary (construction) and permanent loadings that may require modifications to the approach our team will take for the rehabilitation. If any one of these elements are found to be structurally (from a temporary or permanent

load modification) or materially inadequate, it will impact our ability to provide a cost-effective solution to provide for a long-term low maintenance service life and to meet the contract time requirements.

Impact:

If during our preliminary design efforts, or worse, during the actual field work, elements are uncovered that show the material conditions are in worse shape than anticipated there are multiple impacts that our Team will have to take into account that will affect, costs, MOT, design, and schedule:

- **Project Costs:** If during initial design WRA finds areas that the existing elements cannot support construction or permanent loadings or field material issues develop during construction and with the stated RFQ requirements that are ambiguous to the level of work to be undertaken at each sub-structure unit, there is the potential that more work will be required at each substructure unit than what has been anticipated. This will not only increase the proposed bridge work at each location for its rehabilitation, but additional maintenance of traffic will be required to accommodate this work to perform a more extensive repair or, worse case, require a completely new foundations, which will have more impact to I-95 and the final project budgets.
- **Maintenance of Traffic:** Based on the current RFQ requirements, no permanent lane shifts allowed or lane closures are permitted on I-95 and there is virtually no room to plan for shifting of the interstate if an entire pier is found to be required to re-built. If it is determined that an entire pier is required to be re-built, this will require a significant amount of mobilization/demobilization with each shift or potentials for long weekend closures of lanes to “get-in and get-out” along I-95. If an abutment is required to be re-built, not only will the MOT be affected and in place for longer, but the MOT will extend beyond the abutments to accommodate the necessary temporary support of excavation required for the repairs, plus additional impacts to utilities. This will also impact project costs.
- **Geotechnical/Structural Impacts:** The current project RFQ, Section 2.1 Project Overview includes “...abutment modifications, repairs and corrosion mitigation.” The scope of work for the abutment is ambiguous by just stating “modifications” and with the risks of the utilities and their unknown impacts and requirements, this is a significant risk to the level of work associated with the abutment modifications and to make jointless. In addition at the abutments, there is a risk associated with construction loading and crane placements that more backfill material may need to be removed once the superstructure is removed to allow the cranes to sit as close to the bridge as possible without imparting construction loads on the existing foundations that overstress the in-situ element; this may also impacts the utilities. Furthermore, there is a risk to the piers structurally and materially. From a design standpoint, the permanent dead loads may change as our design will remove the joints from the existing bridge and by closure of these joints, the fix/expansion conditions will change from original conditions, which changes the live loads and may overstress the existing piers elements. In addition, once repairs are undertaken in the field (and while defined in the forthcoming RFP), the material condition could be worse than anticipated, a complete pier cap (or entire pier) may need to be replaced. This will lead to significant design and construction delays and more impact to the traveling public with unanticipated MOT requirements to modify the piers in I-95 right-of-way.
- **Completion Schedule:** The proposed project timeline listed in the RFQ will have the project completed in just over three years from NTP for five bridge structures. This is an adequate amount of time if no additional work is found during the scoping and design phase. However, if this additional work is determined to be required during design or is uncovered during demolition, it will be challenging to finish by the contract fixed completion date of December 2024.

Mitigation:

WRA and Corman Kokosing are leaders in bridge design and construction respectively having worked on hundreds of VDOT and municipal bridge projects just like these 5 bridges, including many in the Richmond District and for the City of Richmond. WRA will draw from its over 300 maintenance projects where we have evaluated existing conditions just like these to mitigate these potential risks; this includes over 40 bridges on/over the interstates in the Richmond District alone. We will draw on this knowledge and guidance from Manual of the Structure and Bridge Division, Part 2, Ch. 32 to review what is required for these bridges from a design perspective to help mitigate potential risks during design and anticipate potential construction issues. Our team

will undertake a multi-prong approach to gather the information necessary to make an informed decision to mitigate this risk. For this project, our team has identified these items as part of potential mitigation:

1. Design Mitigation Strategy (Structural Capacities):

With the requirements to eliminate joints for long-term maintenance considerations, there are considerations with the existing pier and the ability to accommodate the additional live load(s). With the change in loading conditions, the piers will require review to ensure that they can handle to modified loads they will experience. To help mitigate these loads, WRA will evaluate the use of alternative bearing types, such as PTFE surfaces to reduce the friction loads that the piers are experiencing. If it is found the existing elements may not be able to resist the modified loads to the columns, Carbon-Fiber wrapping may be used, or special details may be required to address these loads. In addition, WRA will evaluate the use of lightweight concrete to reduce the dead loads. These elements mentioned as mitigation strategies have all been employed on various projects throughout Virginia, including the recently completed I-64 over Chickahominy River where both PTFE and lightweight concrete was used to mitigate new loads on the existing conditions.

2. Material Testing/Conditions:

Our team will review the physical conditions of the substructure units to identify material deterioration and area of risks. Using these results will then allow our team to propose material testing (if deemed appropriate) of these same elements for evaluation of their conditions; such test would include chloride testing, half-cell potential, compressive, freeze-thaw, carbonization, etc. in accordance with S&B guidance. The results of this potential testing will determine the extent of mitigation necessary beyond elements, such as zinc anodes, substandard concrete removal on the piers and or abutments. These results could show that chloride extraction to extend the life of the in-situ bridge elements that will remain may prove cost-effective versus replacement the element under question.

3. Geotechnical Analysis:

Our team will complete a comprehensive foundation analysis and, if significant foundation work is required (retrofitting of the existing foundations, new foundations or foundation replacement), then risks arise from multiple site constraints present at the bridge sites. Our team will mitigate by selecting foundation support options to reduce impacts to I-95 and surrounding roadways. One example is the use of Micropiles for foundation retrofits due the compact equipment size, ability to work in irregular site footprints and minimal vibrations; WRA retrofitted foundation supports on the Rte. 7 over Rte. 267 superstructure replacement, which saved extensive re-building of the existing elements.

4. Utilities/Construction Loadings:

Working with the Lead Utility Coordination Manager, our Structural team will determine the most appropriate solution for sequencing of the bridges to minimize the impacts. In addition, we will work with the Construction Manager to mitigate potential crane loading issues on the approach roadways; this could involve the use of crane mats to help distribute the loading of the cranes, which will also help reduce construction loading to the abutments, all of which will lead to less impacts to the project.

Role of VDOT and other Agencies:

None other than what is expected on a typical Design-Build project for support for approval of design plans to accommodate the proposed project.

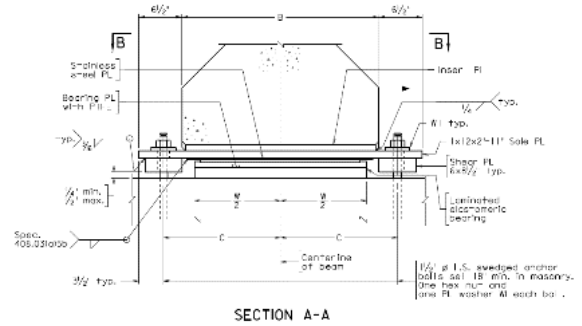

PTFE Bearing – I-64 over Chickahominy River



ATTACHMENT 3.1.2

Contract ID C00111300DB107

STATEMENT OF QUALIFICATIONS CHECKLIST AND CONTENTS

Offerors shall furnish a copy of this Statement of Qualifications (SOQ) Checklist, with the page references added, with the Statement of Qualifications.

Statement of Qualifications Component	Form (if any)	RFQ Cross reference	Included within 15-page limit?	SOQ Page Reference
Statement of Qualifications Checklist and Contents	Attachment 3.1.2	Section 3.1.2	no	Pages 16-18
Acknowledgement of RFQ, Revision and/or Addenda	Attachment 2.10 (Form C-78-RFQ)	Section 2.10	no	Page 19
Letter of Submittal (on Offeror's letterhead)				Page 1
Authorized Representative's signature	NA	Section 3.2.1	yes	Page 1
Offeror's point of contact information	NA	Section 3.2.2	yes	Page 1
Principal officer information	NA	Section 3.2.3	yes	Page 1
Offeror's Corporate Structure	NA	Section 3.2.4	yes	Page 1
Identity of Lead Contractor and Lead Designer	NA	Section 3.2.5	yes	Page 1
Affiliated/subsidiary companies	Attachment 3.2.6	Section 3.2.6	no	Page 20
Debarment forms	Attachment 3.2.7(a) Attachment 3.2.7(b)	Section 3.2.7	no	Pages 21-26
Offeror's VDOT prequalification evidence	NA	Section 3.2.8	no	Page 27
Evidence of obtaining bonding	NA	Section 3.2.9	no	Pages 28-30

ATTACHMENT 3.1.2

Contract ID C00111300DB107

STATEMENT OF QUALIFICATIONS CHECKLIST AND CONTENTS

Statement of Qualifications Component	Form (if any)	RFQ Cross reference	Included within 15-page limit?	SOQ Page Reference
SCC and DPOR registration documentation (Appendix)	Attachment 3.2.10	Section 3.2.10	no	Pages 31-32
Full size copies of SCC Registration	NA	Section 3.2.10.1	no	Pages 33-44
Full size copies of DPOR Registration (Offices)	NA	Section 3.2.10.2	no	Pages 45-61
Full size copies of DPOR Registration (Key Personnel)	NA	Section 3.2.10.3	no	Pages 62-63
Full size copies of DPOR Registration (Non-APELSCIDLA)	NA	Section 3.2.10.4	no	Page 60
DBE statement within Letter of Submittal confirming Offeror is committed to achieving the required DBE goal	NA	Section 3.2.11	yes	Page 1
Offeror's Team Structure				Pages 2-8
Identity of and qualifications of Key Personnel	NA	Section 3.3.1	yes	Pages 3, 5, 7
Key Personnel Resume – DB Project Manager	Attachment 3.3.1	Section 3.3.1.1	no	Pages 64-65
Key Personnel Resume – Quality Assurance Manager	Attachment 3.3.1	Section 3.3.1.2	no	Pages 66-67
Key Personnel Resume – Design Manager	Attachment 3.3.1	Section 3.3.1.3	no	Pages 68-69
Key Personnel Resume – Construction Manager	Attachment 3.3.1	Section 3.3.1.4	no	Pages 70-71
Key Personnel Resume – Lead Utility Coordination Manager	Attachment 3.3.1	Section 3.3.1.4	no	Pages 72-73
Organizational chart	NA	Section 3.3.2	yes	Page 6
Organizational chart narrative	NA	Section 3.3.2	yes	Pages 4-8

ATTACHMENT 3.1.2

Contract ID C00111300DB107

STATEMENT OF QUALIFICATIONS CHECKLIST AND CONTENTS

Statement of Qualifications Component	Form (if any)	RFQ Cross reference	Included within 15-page limit?	SOQ Page Reference
Experience of Offeror's Team				Page 8
Lead Contractor Work History Form	Attachment 3.4.1(a)	Section 3.4	no	Pages 74-76
Lead Designer Work History Form	Attachment 3.4.1(b)	Section 3.4	no	Pages 77-79
Project Risk				Pages 8-15
Identify and discuss three critical risks for the Project	NA	Section 3.5.1	yes	Pages 8-15

ATTACHMENT 2.10

**COMMONWEALTH OF VIRGINIA
DEPARTMENT OF TRANSPORTATION**

RFQ NO. C00111300DB107

PROJECT: I-95 City of Richmond Bridge Superstructure
Replacement and Rehabilitation Bundling

ACKNOWLEDGEMENT OF RFQ, REVISION AND/OR ADDENDA

Acknowledgement shall be made of receipt of the Request for Qualifications (RFQ) and/or any and all revisions and/or addenda pertaining to the above designated project which are issued by the Department prior to the Statement of Qualifications (SOQ) submission date shown herein. Failure to include this acknowledgement in the SOQ may result in the rejection of your SOQ.

By signing this Attachment 2.10, the Offeror acknowledges receipt of the RFQ and/or following revisions and/or addenda to the RFQ for the above designated project which were issued under cover letter(s) of the date(s) shown hereon:

1. Cover letter of RFQ – December 15, 2020
(Date)

2. Cover letter of _____
(Date)

3. Cover letter of _____
(Date)

SIGNATURE

1/29/21
DATE

Greg Hamilton, PE, DBIA
PRINTED NAME

Regional Senior Vice President
TITLE

ATTACHMENT 3.2.6

Contract ID C00111300DB107

Affiliated and Subsidiary Companies of the Offeror

Offerors shall complete the table and include the addresses of affiliates or subsidiary companies as applicable. By completing this table, Offerors certify that all affiliated and subsidiary companies of the Offeror are listed.

- | |
|---|
| <input type="checkbox"/> The Offeror does not have any affiliated or subsidiary companies. |
| <input checked="" type="checkbox"/> Affiliated and/ or subsidiary companies of the Offeror are listed below. |

Relationship with Offeror (Affiliate or Subsidiary)	Full Legal Name	Address
Subsidiaries	Corman Kokosing Real Estate Holdings, LLC	12001 Guilford Road, Annapolis Junction, MD 20701
Subsidiaries	CK – TV, LLC	12001 Guilford Road, Annapolis Junction, MD 20701
Affiliates	Kokosing, Inc.	6235 Westerville Road, Westerville, OH 43081
Affiliates	The Olen Corporation	4755 S High Street, Columbus, OH 43027
Affiliates	Third Gen, Inc.	6235 Westerville Road, Westerville, OH 43081
Affiliates	Corman-Branch, a Joint Venture c/o Corman Kokosing Construction Co.	12001 Guilford Road, Annapolis, MD 20701
Affiliates	Granite-Parsons-Corman Joint Venture c/o Granite Construction Northeast, Inc.	120 White Plains Road, Suite 310, Tarrytown, NY 10591
Affiliates	Skanska-Corman-Mclean Joint Venture	295 Bendix Road, Suite 400, Virginia Beach, VA 23452

ATTACHMENT 3.2.7(a)

CERTIFICATION REGARDING DEBARMENT
PRIMARY COVERED TRANSACTIONS

Contract ID C00111300DB107

1) The prospective primary participant certifies to the best of its knowledge and belief, that it and its principals:

a) Are not presently debarred, suspended, proposed for debarment, declared ineligible, or voluntarily excluded from covered transactions by any Federal department or agency.

b) Have not within a three-year period preceding this proposal been convicted of or had a civil judgment rendered against them for commission of fraud or a criminal offense in connection with obtaining, attempting to obtain, or performing a public (Federal, State or local) transaction or contract under a public transaction; and have not been convicted of any violations of Federal or State antitrust statutes or commission of embezzlement, theft, forgery, bribery, falsification, or destruction of records, making false statements, or receiving stolen property;

c) Are not presently indicted for or otherwise criminally or civilly charged by a governmental entity (Federal, State or local) with commission of any of the offenses enumerated in paragraph 1) b) of this certification; and

d) Have not within a three-year period preceding this application/proposal had one or more public transactions (Federal, State or local) terminated for cause or default.

2) Where the prospective primary participant is unable to certify to any of the statements in this certification, such prospective participant shall attach an explanation to this proposal.

The undersigned makes the foregoing statements to be filed with the proposal submitted on behalf of the Offeror for contracts to be let by the Commonwealth Transportation Board.

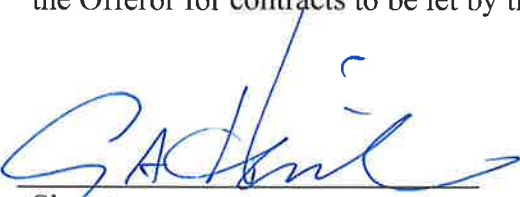
 _____ Signature	1/4/21 _____ Date	Regional Sr. Vice President _____ Title
---	-------------------------	---

Corman Kokosing Construction Company

Name of Firm

ATTACHMENT 3.2.7(b)

CERTIFICATION REGARDING DEBARMENT
LOWER TIER COVERED TRANSACTIONS

Contract ID C00111300DB107

- 1) The prospective lower tier participant certifies, by submission of this proposal, that neither it nor its principals is presently debarred, suspended, proposed for debarment, declared ineligible, or voluntarily excluded from participation in this transaction by any Federal department or agency.

- 2) Where the prospective lower tier participant is unable to certify to any of the statements in this certification, such prospective participant shall attach an explanation to this proposal.

The undersigned makes the foregoing statements to be filed with the proposal submitted on behalf of the Offeror for contracts to be let by the Commonwealth Transportation Board.

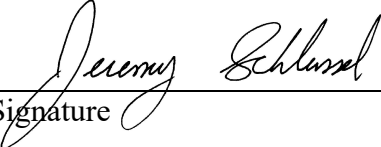
 Signature	1/22/2021 Date	Senior Vice President Title
---	-------------------	--------------------------------

Whitman, Requardt & Associates, LLP
Name of Firm

ATTACHMENT 3.2.7(b)

**CERTIFICATION REGARDING DEBARMENT
LOWER TIER COVERED TRANSACTIONS**

Contract ID C00111300DB107

- 1) The prospective lower tier participant certifies, by submission of this proposal, that neither it nor its principals is presently debarred, suspended, proposed for debarment, declared ineligible, or voluntarily excluded from participation in this transaction by any Federal department or agency.

- 2) Where the prospective lower tier participant is unable to certify to any of the statements in this certification, such prospective participant shall attach an explanation to this proposal.

The undersigned makes the foregoing statements to be filed with the proposal submitted on behalf of the Offeror for contracts to be let by the Commonwealth Transportation Board.



Signature

1/7/2021

Date

President

Title

Athavale, Lystad & Associates, Inc.

Name of Firm

ATTACHMENT 3.2.7(b)

**CERTIFICATION REGARDING DEBARMENT
LOWER TIER COVERED TRANSACTIONS**

Contract ID C00111300DB107

- 1) The prospective lower tier participant certifies, by submission of this proposal, that neither it nor its principals is presently debarred, suspended, proposed for debarment, declared ineligible, or voluntarily excluded from participation in this transaction by any Federal department or agency.

- 2) Where the prospective lower tier participant is unable to certify to any of the statements in this certification, such prospective participant shall attach an explanation to this proposal.

The undersigned makes the foregoing statements to be filed with the proposal submitted on behalf of the Offeror for contracts to be let by the Commonwealth Transportation Board.



Signature

January 13, 2021

Date

Vice President

Title

H & B Surveying and Mapping, LLC

Name of Firm

ATTACHMENT 3.2.7(b)

CERTIFICATION REGARDING DEBARMENT
LOWER TIER COVERED TRANSACTIONS

Contract ID C00111300DB107

- 1) The prospective lower tier participant certifies, by submission of this proposal, that neither it nor its principals is presently debarred, suspended, proposed for debarment, declared ineligible, or voluntarily excluded from participation in this transaction by any Federal department or agency.
- 2) Where the prospective lower tier participant is unable to certify to any of the statements in this certification, such prospective participant shall attach an explanation to this proposal.

The undersigned makes the foregoing statements to be filed with the proposal submitted on behalf of the Offeror for contracts to be let by the Commonwealth Transportation Board.

	1/22/21	PRESIDENT
Signature	Date	Title

KDR REAL ESTATE SERVICES, INC.

Name of Firm

ATTACHMENT 3.2.7(b)

**CERTIFICATION REGARDING DEBARMENT
LOWER TIER COVERED TRANSACTIONS**

Contract ID C00111300DB107

- 1) The prospective lower tier participant certifies, by submission of this proposal, that neither it nor its principals is presently debarred, suspended, proposed for debarment, declared ineligible, or voluntarily excluded from participation in this transaction by any Federal department or agency.

- 2) Where the prospective lower tier participant is unable to certify to any of the statements in this certification, such prospective participant shall attach an explanation to this proposal.

The undersigned makes the foregoing statements to be filed with the proposal submitted on behalf of the Offeror for contracts to be let by the Commonwealth Transportation Board.

Michael W. Saunders
Signature

1/18/2021
Date

Senior Vice President
Title

Century Engineering, Inc. d/b/a NXL
Name of Firm



Department's List of Prequalified Vendors
Includes All Qualified Levels As Of 12/16/2020

- C -

Vendor ID: C1094
Vendor Name: CORINTHIAN CONTRACTORS, INC.
Prequal Level: Prequalified (Currently Inactive)
Prequal Exp: 03/31/2021

-- PREQ Address --

8510 WESTPHALIA RD.
UPPER MARLBORO, MD 20772
Phone: (301)568-6510
Fax: (301)568-6515

Work Classes (Listed But Not Limited To)

002 - GRADING
007 - MINOR STRUCTURES
045 - UNDERGROUND UTILITIES

Bus. Contact: MUNSLow, DECLAN CIERAN
Email: DMUNSLow@CORINTHIANCONTRACTORS.COM

-- DBE Information --

DBE Type: N/A
DBE Contact: N/A

Vendor ID: C3607
Vendor Name: CORMAN KOKOSING CONSTRUCTION COMPANY
Prequal Level: Prequalified
Prequal Exp: 03/31/2021

-- PREQ Address --

12001 GUILFORD ROAD
ANNAPOLIS JUNCTION, MD 20701
Phone: (301)953-0900
Fax: (301)953-0384

Work Classes (Listed But Not Limited To)

002 - GRADING
003 - MAJOR STRUCTURES
007 - MINOR STRUCTURES
045 - UNDERGROUND UTILITIES

Bus. Contact: SCHEELE, SHAWN MICHAEL
Email: SSCHEELE@CORMANCONSTRUCTION.COM

-- DBE Information --

DBE Type: N/A
DBE Contact: N/A



Carolyn E. Wheeler

Marsh USA Inc.
1111 Northshore Drive
Suite N550
Knoxville, TN 37919
865-769-7787
Carolyn.E.Wheeler@marsh.com
www.marsh.com

Joseph A. Clarke, PE, DBIA
Alternative Project Delivery Division
Virginia Department of Transportation
1401 East Broad Street, Richmond, VA 23219

January 13, 2021

Subject: Corman Kokosing Construction Company – Design Build Project
I-95 City of Richmond Bridge Superstructure Replacement and Rehabilitation Bundling
UPC (State Project Nos.; Federal Project Nos.)
UPC 111300 (U000-127-023, P101, R201, C501, B601; STP-BR04(287))
UPC 111294 (0064-127-022, P101, B661; NHPP-064-3(510))
UPC 113375 (0250-127-050, P101, R201, C501; NHPP-BR04(307))
UPC 113388 (0004-127-051, P101, R201, C501; NHPP-BR04(308))
7th Street Bridge - Contract ID Number: C00111300DB107

This letter will confirm that Corman Kokosing Construction Company is highly regarded by and prequalified with its surety companies, Liberty Mutual Insurance Company (A.M. Best Rating A, XV) and Travelers Casualty and Surety Company of America (A.M. Best Rating A++, XV), co-sureties for Corman Kokosing Construction Company. Corman Kokosing Construction Company is capable of providing bonds for projects in excess of \$500 million with aggregate contracts exceeding \$3 billion. These single project size and aggregate capacity levels are by no means meant to imply a maximum capacity level and should larger capacity amounts be necessary the underwriters are favorable toward providing Corman Kokosing Construction Company with higher support levels.

This letter also confirms that Corman Kokosing Construction Company is capable of providing 100% Performance Bond and 100% Labor and Materials Payment Bond in the amount of \$37,000,000, which is the current estimated contract value for the referenced project, and said bonds will cover the Project and any warranty periods as provided for in the contract documents on behalf of Corman Kokosing Construction Company, in the event they are the successful bidder and enter into a contract for this Project.

This pre-qualification is conditioned on acceptable underwriting considerations such as final contract terms and condition, bond forms and final project details.

We are proud to be a part of the Corman Kokosing Construction Company risk management and surety team. Should you have any questions or if you need any clarification, please do not hesitate to contact me.

Sincerely,



Carolyn E. Wheeler, Attorney-in-Fact
Liberty Mutual Insurance Company
Travelers Casualty and Surety Company of America

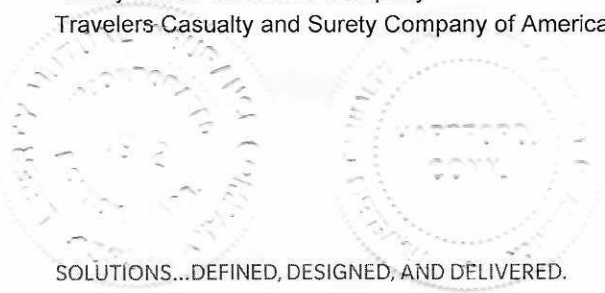

SOLUTIONS...DEFINED, DESIGNED, AND DELIVERED.





This Power of Attorney limits the acts of those named herein, and they have no authority to bind the Company except in the manner and to the extent herein stated.

Liberty Mutual Insurance Company
The Ohio Casualty Insurance Company
West American Insurance Company

Certificate No: 8201331

POWER OF ATTORNEY

KNOWN ALL PERSONS BY THESE PRESENTS: That The Ohio Casualty Insurance Company is a corporation duly organized under the laws of the State of New Hampshire, that Liberty Mutual Insurance Company is a corporation duly organized under the laws of the State of Massachusetts, and West American Insurance Company is a corporation duly organized under the laws of the State of Indiana (herein collectively called the "Companies"), pursuant to and by authority herein set forth, does hereby name, constitute and appoint, Carolyn E. Wheeler all of the city of Knoxville, state of Tennessee each individually if there be more than one named, its true and lawful attorney-in-fact, with full power and authority hereby conferred to sign, execute and acknowledge the above-referenced surety bond.

IN WITNESS WHEREOF, this Power of Attorney has been subscribed by an authorized officer or official of the Companies and the corporate seals of the Companies have been affixed thereto this 30th day of May, 2019.

Liberty Mutual Insurance Company
The Ohio Casualty Insurance Company
West American Insurance Company



By: [Signature of David M. Carey]

David M. Carey, Assistant Secretary

STATE OF PENNSYLVANIA ss
COUNTY OF MONTGOMERY

On this 30th day of May, 2019, before me personally appeared David M. Carey, who acknowledged himself to be the Assistant Secretary of Liberty Mutual Insurance Company, The Ohio Casualty Company, and West American Insurance Company, and that he, as such, being authorized so to do, execute the foregoing instrument for the purposes therein contained by signing on behalf of the corporations by himself as a duly authorized officer.

IN WITNESS WHEREOF, I have hereunto subscribed my name and affixed my notarial seal at King of Prussia, Pennsylvania, on the day and year first above written.



COMMONWEALTH OF PENNSYLVANIA
Notarial Seal
Teresa Pastella, Notary Public
Upper Merion Twp., Montgomery County
My Commission Expires March 28, 2021
Member, Pennsylvania Association of Notaries

By: [Signature of Teresa Pastella]
Teresa Pastella, Notary Public

This Power of Attorney is made and executed pursuant to and by authority of the following By-laws and Authorizations of The Ohio Casualty Insurance Company, Liberty Mutual Insurance Company, and West American Insurance Company which resolutions are now in full force and effect reading as follows:

ARTICLE IV - OFFICERS: Section 12. Power of Attorney.

Any officer or other official of the Corporation authorized for that purpose in writing by the Chairman or the President, and subject to such limitation as the Chairman or the President may prescribe, shall appoint such attorneys-in-fact, as may be necessary to act in behalf of the Corporation to make, execute, seal, acknowledge and deliver as surety any and all undertakings, bonds, recognizances and other surety obligations. Such attorneys-in-fact, subject to the limitations set forth in their respective powers of attorney, shall have full power to bind the Corporation by their signature and execution of any such instruments and to attach thereto the seal of the Corporation. When so executed, such instruments shall be as binding as if signed by the President and attested to by the Secretary. Any power or authority granted to any representative or attorney-in-fact under the provisions of this article may be revoked at any time by the Board, the Chairman, the President or by the officer or officers granting such power or authority.

ARTICLE XIII - Execution of Contracts: Section 5. Surety Bonds and Undertakings.

Any officer of the Company authorized for that purpose in writing by the chairman or the president, and subject to such limitations as the chairman or the president may prescribe, shall appoint such attorneys-in-fact, as may be necessary to act in behalf of the Company to make, execute, seal, acknowledge and deliver as surety any and all undertakings, bonds, recognizances and other surety obligations. Such attorneys-in-fact, subject to the limitations set forth in their respective powers of attorney, shall have full power to bind the Company by their signature and execution of any such instruments and to attach thereto the seal of the Company. When so executed such instruments shall be as binding as if signed by the president and attested by the secretary.

Certificate of Designation - The President of the Company, acting pursuant to the Bylaws of the Company, authorizes David M. Carey, Assistant Secretary to appoint such attorneys-in-fact as may be necessary to act on behalf of the Company to make, execute, seal, acknowledge and deliver as surety any and all undertakings, bonds, recognizances and other surety obligations.

Authorization - By unanimous consent of the Company's Board of Directors, the Company consents that facsimile or mechanically reproduced signature of any assistant secretary of the Company, wherever appearing upon a certified copy of any power of attorney issued by the Company in connection with surety bonds, shall be valid and binding upon the Company with the same force and effect as though manually affixed.

I, Renee C. Llewellyn, the undersigned, Assistant Secretary, of Liberty Mutual Insurance Company, The Ohio Casualty Insurance Company, and West American Insurance Company do hereby certify that this power of attorney executed by said Companies is in full force and effect and has not been revoked.

IN TESTIMONY WHEREOF, I have hereunto set my hand and affixed the seals of said Companies this 13th day of January, 2021.



By: [Signature of Renee C. Llewellyn]

Renee C. Llewellyn, Assistant Secretary

Not valid for mortgage, note, loan, letter of credit, currency rate, interest rate or residual value guarantees.

To confirm the validity of this Power of Attorney call 1-610-832-8240 between 9:00am and 4:30pm EST on any business day.



**Travelers Casualty and Surety Company of America
Travelers Casualty and Surety Company
St. Paul Fire and Marine Insurance Company**

POWER OF ATTORNEY

KNOW ALL MEN BY THESE PRESENTS: That Travelers Casualty and Surety Company of America, Travelers Casualty and Surety Company, and St. Paul Fire and Marine Insurance Company are corporations duly organized under the laws of the State of Connecticut (herein collectively called the "Companies"), and that the Companies do hereby make, constitute and appoint Carolyn E. Wheeler, of Knoxville Tennessee, their true and lawful Attorney-in-Fact to sign, execute, seal and acknowledge any and all bonds, recognizances, conditional undertakings and other writings obligatory in the nature thereof on behalf of the Companies in their business of guaranteeing the fidelity of persons, guaranteeing the performance of contracts and executing or guaranteeing bonds and undertakings required or permitted in any actions or proceedings allowed by law.

IN WITNESS WHEREOF, the Companies have caused this instrument to be signed, and their corporate seals to be hereto affixed, this **3rd** day of **February**, 2017.



State of Connecticut

City of Hartford ss.

By:
Robert L. Raney, Senior Vice President

On this the **3rd** day of **February**, 2017, before me personally appeared **Robert L. Raney**, who acknowledged himself to be the Senior Vice President of Travelers Casualty and Surety Company of America, Travelers Casualty and Surety Company, and St. Paul Fire and Marine Insurance Company, and that he, as such, being authorized so to do, executed the foregoing instrument for the purposes therein contained by signing on behalf of the corporations by himself as a duly authorized officer.

In Witness Whereof, I hereunto set my hand and official seal.

My Commission expires the **30th** day of **June**, 2021



Marie C. Tetreault, Notary Public

This Power of Attorney is granted under and by the authority of the following resolutions adopted by the Boards of Directors of Travelers Casualty and Surety Company of America, Travelers Casualty and Surety Company, and St. Paul Fire and Marine Insurance Company, which resolutions are now in full force and effect, reading as follows:

RESOLVED, that the Chairman, the President, any Vice Chairman, any Executive Vice President, any Senior Vice President, any Vice President, any Second Vice President, the Treasurer, any Assistant Treasurer, the Corporate Secretary or any Assistant Secretary may appoint Attorneys-in-Fact and Agents to act for and on behalf of the Company and may give such appointee such authority as his or her certificate of authority may prescribe to sign with the Company's name and seal with the Company's seal bonds, recognizances, contracts of indemnity, and other writings obligatory in the nature of a bond, recognizance, or conditional undertaking, and any of said officers or the Board of Directors at any time may remove any such appointee and revoke the power given him or her; and it is

FURTHER RESOLVED, that the Chairman, the President, any Vice Chairman, any Executive Vice President, any Senior Vice President or any Vice President may delegate all or any part of the foregoing authority to one or more officers or employees of this Company, provided that each such delegation is in writing and a copy thereof is filed in the office of the Secretary; and it is

FURTHER RESOLVED, that any bond, recognizance, contract of indemnity, or writing obligatory in the nature of a bond, recognizance, or conditional undertaking shall be valid and binding upon the Company when (a) signed by the President, any Vice Chairman, any Executive Vice President, any Senior Vice President or any Vice President, any Second Vice President, the Treasurer, any Assistant Treasurer, the Corporate Secretary or any Assistant Secretary and duly attested and sealed with the Company's seal by a Secretary or Assistant Secretary; or (b) duly executed (under seal, if required) by one or more Attorneys-in-Fact and Agents pursuant to the power prescribed in his or her certificate or their certificates of authority or by one or more Company officers pursuant to a written delegation of authority; and it is

FURTHER RESOLVED, that the signature of each of the following officers: President, any Executive Vice President, any Senior Vice President, any Vice President, any Assistant Vice President, any Secretary, any Assistant Secretary, and the seal of the Company may be affixed by facsimile to any Power of Attorney or to any certificate relating thereto appointing Resident Vice Presidents, Resident Assistant Secretaries or Attorneys-in-Fact for purposes only of executing and attesting bonds and undertakings and other writings obligatory in the nature thereof, and any such Power of Attorney or certificate bearing such facsimile signature or facsimile seal shall be valid and binding upon the Company and any such power so executed and certified by such facsimile signature and facsimile seal shall be valid and binding on the Company in the future with respect to any bond or understanding to which it is attached.

I, **Kevin E. Hughes**, the undersigned, Assistant Secretary of Travelers Casualty and Surety Company of America, Travelers Casualty and Surety Company, and St. Paul Fire and Marine Insurance Company, do hereby certify that the above and foregoing is a true and correct copy of the Power of Attorney executed by said Companies, which remains in full force and effect.

Dated this 13th day of January, 2021



Kevin E. Hughes, Assistant Secretary

**To verify the authenticity of this Power of Attorney, please call us at 1-800-421-3880.
Please refer to the above-named Attorney-in-Fact and the details of the bond to which the power is attached.**

Marsh

ATTACHMENT 3.2.10

Contract ID C00111300DB107

SCC and DPOR Information

Offerors shall complete the table and include the required state registration and licensure information. By completing this table, Offerors certify that their team complies with the requirements set forth in Section 3.2.10 and that all businesses and individuals listed are active and in good standing.

SCC & DPOR INFORMATION FOR BUSINESSES (RFQ Sections 3.2.10.1 and 3.2.10.2)							
Business Name	SCC Information (3.2.10.1)			DPOR Information (3.2.10.2)			
	SCC Number	SCC Type of Corporation	SCC Status	DPOR Registered Address	DPOR Registration Type	DPOR Registration Number	DPOR Expiration Date
Corman-Kokosing Construction Company	F2080481	Corporation	Active	12001 Guilford Road Annapolis Junction, MD 20701	Class A Contractor	2705167185	02/28/2022
Whitman, Requardt & Associates, LLP	K000382-4	Limited Liability Partnership	Active	9030 Stony Point Parkway, Suite 220 Richmond, VA 23235	ENG	0411000133	02/28/2022
Whitman, Requardt & Associates, LLP	K000382-4	Limited Liability Partnership	Active	801 South Caroline Street Baltimore, MD 21231	ENG, LS, ARC, LA	0407001676	12/31/2021
Whitman, Requardt & Associates, LLP	K000382-4	Limited Liability Partnership	Active	1700 Kraft Drive, Suite 1200 Blacksburg, VA 24060	ENG	0411000608	02/28/2022
Whitman, Requardt & Associates, LLP	K000382-4	Limited Liability Partnership	Active	100 5 th Street, Suite L2000 Bristol, TN 37620	ENG	0411001228	02/28/2022
Whitman, Requardt & Associates, LLP	K000382-4	Limited Liability Partnership	Active	300 Summers Street, Suite 810 Charleston, WV 25301	ENG	0411001412	02/28/2022
Whitman, Requardt & Associates, LLP	K000382-4	Limited Liability Partnership	Active	12700 Fair Lakes Circle, #300 Fairfax, VA 22033	ENG	0411000134	02/28/2022
Whitman, Requardt & Associates, LLP	K000382-4	Limited Liability Partnership	Active	1320 Central Park Boulevard, Suite 224 Fredericksburg, VA 22401	ENG	0411000861	02/28/2022
Whitman, Requardt & Associates, LLP	K000382-4	Limited Liability Partnership	Active	1705 Enterprise Drive, Suite 100 Lynchburg, VA 24502	ENG	0411000774	02/28/2022
Whitman, Requardt & Associates, LLP	K000382-4	Limited Liability Partnership	Active	11870 Merchants Walk, Suite 100 Newport News, VA 23606	ENG	0411000244	02/28/2022
Whitman, Requardt & Associates, LLP	K000382-4	Limited Liability Partnership	Active	2009 Mackenzie Way, Suite 240 Cranberry Township, PA 16066	ENG	0411000830	02/28/2022
Whitman, Requardt & Associates, LLP	K000382-4	Limited Liability Partnership	Active	1201 Edwards Mill Road, Suite 320 Raleigh, NC 27607	ENG	0411001602	02/28/2022
Whitman, Requardt & Associates, LLP	K000382-4	Limited Liability Partnership	Active	5701 Cleveland Street, Suite 620 Virginia Beach, VA 23462	ENG	0411000908	02/28/2022
Athavale, Lystad & Associates, Inc.	F0605842	Corporation	Active	8180 Greensboro Drive, # 550 McLean, VA 22102	ENG	0407002804	12/31/2021
H&B Surveying and Mapping, LLC	S2905604	Limited Liability Corporation	Active	614 Moorefield Park Drive Richmond, VA 23236	LS	0407005432	12/31/2021

ATTACHMENT 3.2.10

Contract ID C00111300DB107

SCC and DPOR Information

KDR Real Estate Services, Inc.	05712104	Corporation	Active	2500 Grenoble Road Richmond, VA 23294	Real Estate	0226007129	12/31/2022
Century Engineering, Inc. (d/b/a/ NXL)	F1909839	Corporation	Active	114 East Cary Street, Suite 200 Richmond, VA 23219	ENG, LS	0411001489	02/28/2022

DPOR INFORMATION FOR INDIVIDUALS (RFQ Sections 3.2.10.3 and 3.2.10.4)

Business Name	Individual's Name	Office Location Where Professional Services will be Provided (City/State)	Individual's DPOR Address	DPOR Type	DPOR Registration Number	DPOR Expiration Date
Century Engineering, Inc. (d/b/a/ NXL)	Mike Saunders	Richmond, VA	4500 Litchfield Drive Chesterfield, VA 23832	Professional Engineer	0402041295	12/31/2021
Whitman, Requardt & Associates, LLP	Jeremy Schlusel	Richmond, VA	9105 Carrington Hills Court Glen Allen, VA 23060	Professional Engineer	0402033974	01/31/2022

Entity Information

Entity Information

Entity Name: Corman Kokosing Construction Company
Entity ID: F2080481
Entity Type: Stock Corporation
Entity Status: **Active**
Formation Date: N/A
Reason for Status: Active and In Good Standing
VA Qualification Date: 01/22/2018
Status Date: 02/28/2019
Industry Code: 0 - General
Period of Duration: Perpetual
Jurisdiction: OH
Annual Report Due Date: N/A
Registration Fee Due Date: Not Required
Charter Fee: \$100.00

Registered Agent Information

RA Type: Entity
Locality: HENRICO COUNTY
RA Qualification: BUSINESS ENTITY THAT IS AUTHORIZED TO
TRANSACTION BUSINESS IN VIRGINIA
Name: C T CORPORATION SYSTEM
Registered Office Address: 4701 Cox Rd Ste 285, Glen Allen, VA, 23060 - 6808,
USA

Principal Office Address

Address: 12001 Guilford Rd, Annapolis Junction, MD, 20701
1201 USA
Privacy Policy (<https://www.scc.virginia.gov/privacy.aspx>) | Contact Us

(https://www.scc.virginia.gov/clk/clk_contact.aspx)

Commonwealth of Virginia



State Corporation Commission

CERTIFICATE OF FACT

I Certify the Following from the Records of the Commission:

On August 10, 2000, WHITMAN, REQUARDT & ASSOCIATES, LLP, a Maryland registered limited liability partnership, filed in the Clerk's Office of the Commission a statement of registration as a foreign registered limited liability partnership.

As of the date below, statement of cancellation have not been filed in this office by WHITMAN, REQUARDT & ASSOCIATES, LLP, this statement of registration is in effect.

Nothing more is hereby certified.



Signed and Sealed at Richmond on this Date:

July 17, 2020

A handwritten signature in cursive script, reading "Bernard J. Logan".

Bernard J. Logan, Interim Clerk of the Commission



COMMONWEALTH OF VIRGINIA
STATE CORPORATION COMMISSION

Office of the Clerk

July 17, 2020

John Maddox
9030 Stony Point Parkway Suite 220
Richmond, VA, 23235

RECEIPT

RE: WHITMAN, REQUARDT & ASSOCIATES, LLP
ID: K0003824
WORK ORDER NO: 202007160787958

Dear Customer:

This is your receipt for \$6.00 to cover the fee for requesting a certificate of fact with this office.

If you have any questions, please call (804) 371-9733 or toll-free in Virginia, (866) 722-2551.

Sincerely,

Bernard J. Logan
Interim Clerk of the Commission

RECEIVED

JUL 20 2020

WHITMAN, REQUARDT
AND ASSOCIATES, LLP

Delivery Method: Mail

Entity Information

Entity Information

Entity Name: ATHAVALLE, LYSTAD & ASSOCIATES, INC.

Entity ID: F0605842

Entity Type: Stock Corporation

Entity Status: **Active**

Formation Date: N/A

Reason for Status: Active and In Good Standing

VA Qualification Date: 03/02/1989

Status Date: 03/02/1989

Industry Code: 0 - General

Period of Duration: Perpetual

Jurisdiction: MD

Annual Report Due Date: 03/31/2021

Registration Fee Due Date: 03/31/2021

Charter Fee: \$0.00

Registered Agent Information

RA Type: Entity

Locality: FAIRFAX COUNTY

RA Qualification: BUSINESS ENTITY THAT IS AUTHORIZED TO
TRANSACTION BUSINESS IN VIRGINIA

Name: Rees Broome, PC

Registered Office Address: 1900 GALLOWS RD STE 700, TYSONS
CORNER, VA, 22182 - 0000, USA

[Privacy Policy \(https://www.scc.virginia.gov/privacy.aspx\)](https://www.scc.virginia.gov/privacy.aspx) | [Contact Us](#)

https://www.scc.virginia.gov/alk/alk_contact.aspx

Commonwealth of Virginia



State Corporation Commission

I Certify the Following from the Records of the Commission:

ATHAVALA, LYSTAD & ASSOCIATES, INC., a corporation existing under the laws of MARYLAND, holds a certificate of authority to transact business in Virginia, and is in good standing.

The certificate was issued on March 02, 1989.

Nothing more is hereby certified.



*Signed and Sealed at Richmond on this Date:
August 24, 2009*

Joel H. Peck

Joel H. Peck, Clerk of the Commission

Entity Information

Entity Information

Entity Name: H & B Surveying and Mapping, LLC

Entity ID: S2905604

Entity Type: Limited Liability Company

Entity Status: **Active**

Formation Date: 04/27/2009

Reason for Status: Active

VA Qualification Date: 04/27/2009

Status Date: 04/27/2009

Industry Code: 0 - General

Period of Duration: Perpetual

Jurisdiction: VA

Annual Report Due Date: N/A

Registration Fee Due Date: Not Required

Charter Fee: N/A

Registered Agent Information

RA Type: Individual

Locality: HENRICO COUNTY

RA Qualification: Member of the Virginia State Bar

Name: TIMOTHY H GUARE

Registered Office Address: TIMOTHY H GUARE PLC, 6802 PARAGON PL
STE 100, HENRICO, VA, 23230 - 0000, USA

Principal Office Address | [Privacy Policy \(https://www.scc.virginia.gov/privacy.aspx\)](https://www.scc.virginia.gov/privacy.aspx) | [Contact Us](#)

(https://www.scc.virginia.gov/alk/alk_contact.aspx)

Commonwealth of Virginia



STATE CORPORATION COMMISSION

Richmond, April 27, 2009

This is to certify that the certificate of organization of

H & B Surveying and Mapping, LLC

was this day issued and admitted to record in this office and that the said limited liability company is authorized to transact its business subject to all Virginia laws applicable to the company and its business. Effective date: April 27, 2009



State Corporation Commission

Attest:

Joel H. Beck
Clerk of the Commission

SCC ID: S2905604

Entity Information

Entity Information

Entity Name: KDR Real Estate Services, Inc.

Entity ID: 05712104

Entity Type: Stock Corporation

Entity Status: **Active**

Formation Date: 01/30/2002

Reason for Status: Active and In Good Standing

VA Qualification Date: 01/30/2002

Status Date: 07/07/2003

Industry Code: 0 - General

Period of Duration: Perpetual

Jurisdiction: VA

Annual Report Due Date: N/A

Registration Fee Due Date: Not Required

Charter Fee: \$50.00

Registered Agent Information

RA Type: Individual

Locality: HENRICO COUNTY

RA Qualification: Officer of the Corporation

Name: ALLEN G DORIN JR

Registered Office Address: 2500 GRENOBLE RD, RICHMOND, VA, 23294 -
0000, USA

Principal Office Address | [Privacy Policy \(https://www.scc.virginia.gov/privacy.aspx\)](https://www.scc.virginia.gov/privacy.aspx) | [Contact Us](#)

(https://www.scc.virginia.gov/alk/alk_contact.aspx)

Commonwealth of Virginia



STATE CORPORATION COMMISSION

Richmond, January 30, 2002

This is to Certify that the certificate of incorporation of

KDR Real Estate Services, Inc.

was this day issued and admitted to record in this office and that the said corporation is authorized to transact its business subject to all Virginia laws applicable to the corporation and its business. Effective date: January 30, 2002



State Corporation Commission

Attest:

Joel H. Beck

Clerk of the Commission

Entity Information

Entity Information

Entity Name: Century Engineering Inc., a Maryland based corporation
 Entity ID: F1909839
 Entity Type: Stock Corporation
 Entity Status: **Active**
 Formation Date: N/A
 Reason for Status: Active and In Good Standing
 VA Qualification Date: 10/05/2012
 Status Date: 11/13/2020
 Industry Code: 0 - General
 Period of Duration: Perpetual
 Jurisdiction: MD
 Annual Report Due Date: N/A
 Registration Fee Due Date: Not Required
 Charter Fee: \$2500.00

Registered Agent Information

RA Type: Entity
 Locality: HANOVER COUNTY
 RA Qualification: BUSINESS ENTITY THAT IS AUTHORIZED TO TRANSACT BUSINESS IN VIRGINIA
 Name: INCORP SERVICES, INC.
 Registered Office Address: 7288 HANOVER GREEN DRIVE,
 MECHANICSVILLE, VA, 23111 - 0000, USA

[Privacy Policy \(https://www.scc.virginia.gov/privacy.aspx\)](https://www.scc.virginia.gov/privacy.aspx)

[Contact Us](https://www.scc.virginia.gov/alk/alk_contact.aspx)

(https://www.scc.virginia.gov/alk/alk_contact.aspx)

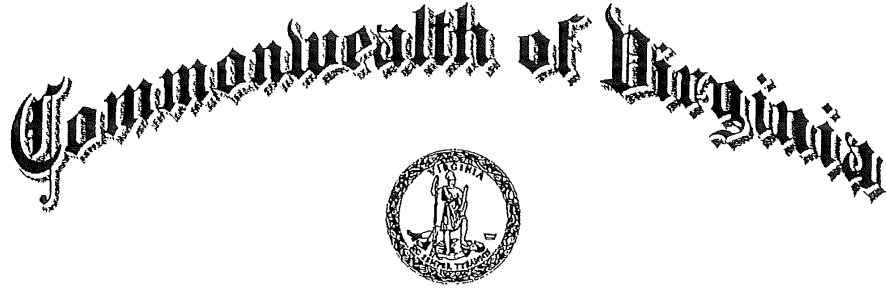

STATE CORPORATION COMMISSION

Richmond, October 5, 2012

This is to certify that a certificate of authority to transact business in Virginia was this day issued and admitted to record in this office for

Century Engineering Inc., a Maryland based corporation (USED IN VA BY: Century Engineering, I

a corporation organized under the laws of MARYLAND and that the said corporation is authorized to transact business in Virginia, subject to all Virginia laws applicable to the corporation and its business.



State Corporation Commission

Attest:

Joel H. Beck
Clerk of the Commission



COMMONWEALTH OF VIRGINIA
STATE CORPORATION COMMISSION

Office of the Clerk

October 5, 2012

LISA A SCHRACK
CENTURY ENGINEERING
10710 GILROY RD
HUNT VALLEY, MD 21031

RECEIPT

RE: Century Engineering Inc., a Maryland based
corporation (USED IN VA BY: Century Engineering, I
ID: F190983 - 9
DCN: 12-09-25-0020

Dear Customer:

This is your receipt for \$2,525.00, to cover the fees for filing an application for a certificate of authority to transact business in Virginia with this office.

The effective date of the certificate is October 5, 2012.

If you have any questions, please call (804) 371-9733 or toll-free in Virginia, 1-866-722-2551.

Sincerely,

Joel H. Peck
Clerk of the Commission

CORFACPT
CIS0313

P.O. Box 1197, Richmond, VA 23218-1197
Tyler Building, First Floor, 1300 East Main Street, Richmond, VA 23219-3630
Clerk's Office (804) 371-9733 or (866) 722-2551 (toll-free in Virginia) www.scc.virginia.gov/clk
Telecommunications Device for the Deaf-TDD/Voice: (804) 371-9206

COMMONWEALTH of VIRGINIA

Department of Professional and Occupational Regulation

9960 Mayland Drive, Suite 400, Richmond, VA 23233

Telephone: (804) 367-8500

EXPIRES ON
02-28-2022

NUMBER
2705167185

BOARD FOR CONTRACTORS
CLASS A CONTRACTOR
CLASSIFICATIONS H/H MCC



CORMAN KOKOSING CONSTRUCTION COMPANY
12001 GUILFORD RD
ANNAPOLIS JUNCTION, MD 20701



Mary Broz-Vaughan
Mary Broz-Vaughan, Director

Status can be verified at <http://www.dpor.virginia.gov>

(SEE REVERSE SIDE FOR PRIVILEGES AND INSTRUCTIONS)

DPOR-LIC (02/2017)

(DETACH HERE)

 COMMONWEALTH of VIRGINIA
Department of Professional and Occupational Regulation

CLASS A BOARD FOR CONTRACTORS
CONTRACTOR

CLASSIFICATIONS H/H MCC
NUMBER: 2705167185 EXPIRES: 02-28-2022



(FOLD)

COMMONWEALTH of VIRGINIA

Department of Professional and Occupational Regulation

9960 Mayland Drive, Suite 400, Richmond, VA 23233

Telephone: (804) 367-8500

EXPIRES ON
02-28-2022

NUMBER
0411000133

BOARD FOR ARCHITECTS, PROFESSIONAL ENGINEERS, LAND SURVEYORS, CERTIFIED INTERIOR DESIGNERS
AND LANDSCAPE ARCHITECTS
BUSINESS ENTITY BRANCH OFFICE REGISTRATION

PROFESSIONS: ENG



WHITMAN REQUARDT AND ASSOCIATES
9030 STONY POINT PKWY STE 220
RICHMOND, VA 23235



Mary Broz-Vallman
Mary Broz-Vallman, Director

Status can be verified at <http://www.dpor.virginia.gov>

(SEE REVERSE SIDE FOR PRIVILEGES AND INSTRUCTIONS)

DPOR-LIC (02/2017)

(DETACH HERE)

DPOR COMMONWEALTH of VIRGINIA
Department of Professional and Occupational Regulation

BOARD FOR AP/ELSC/DLA
BUSINESS ENTITY BRANCH OFFICE REGISTRATION
NUMBER: 0411000133 EXPIRES: 02-28-2022
PROFESSIONS: ENG
WHITMAN REQUARDT AND ASSOCIATES
9030 STONY POINT PKWY STE 220
RICHMOND, VA 23235



(FOLD)

Status can be verified at <http://www.dpor.virginia.gov>

DPOR-PC (02/2017)

COMMONWEALTH of VIRGINIA

Department of Professional and Occupational Regulation

9960 Mayland Drive, Suite 400, Richmond, VA 23233

Telephone: (804) 367-8500

EXPIRES ON
12-31-2021

NUMBER
0407001676

BOARD FOR ARCHITECTS, PROFESSIONAL ENGINEERS, LAND SURVEYORS, CERTIFIED INTERIOR DESIGNERS
AND LANDSCAPE ARCHITECTS
BUSINESS ENTITY REGISTRATION

PROFESSIONS: ENG, LS, ARC, LA



WHITMAN, REQUARDT AND ASSOCIATES LLP
801 SOUTH CAROLINE ST
BALTIMORE, MD 21231



Mary Broz-Vaughan
Mary Broz-Vaughan, Director

Status can be verified at <http://www.dpor.virginia.gov>

(SEE REVERSE SIDE FOR PRIVILEGES AND INSTRUCTIONS)

DPOR-LIC (02/2017)

(DETACH HERE)



COMMONWEALTH of VIRGINIA
Department of Professional and Occupational Regulation

BOARD FOR APELSCIDLA
BUSINESS ENTITY REGISTRATION
NUMBER: 0407001676 EXPIRES: 12-31-2021
PROFESSIONS: ENG, LS, ARC, LA
WHITMAN, REQUARDT AND ASSOCIATES LLP
801 SOUTH CAROLINE ST
BALTIMORE, MD 21231



(FOLD)

VOID

Status can be verified at <http://www.dpor.virginia.gov>

DPOR-PC (02/2017)

PATENTS 5 187 785 5 342 158

COMMONWEALTH of VIRGINIA

Department of Professional and Occupational Regulation

9960 Mayland Drive, Suite 400, Richmond, VA 23233

Telephone: (804) 367-8500

EXPIRES ON

02-28-2022

NUMBER

0411000608

BOARD FOR ARCHITECTS, PROFESSIONAL ENGINEERS, LAND SURVEYORS, CERTIFIED INTERIOR DESIGNERS
AND LANDSCAPE ARCHITECTS
BUSINESS ENTITY BRANCH OFFICE REGISTRATION

PROFESSIONS - ENG



WHITMAN REQUARDT & ASSOCIATES LLP

1700 KRAFT DRIVE

SUITE 1200

BLACKSBURG, VA 24060



Mary Broz-Veughan
Mary Broz-Veughan, Director

Status can be verified at <http://www.dpor.virginia.gov>

(SEE REVERSE SIDE FOR PRIVILEGES AND INSTRUCTIONS)

DPOR-LIC (02/2017)

COMMONWEALTH of VIRGINIA

Department of Professional and Occupational Regulation

9960 Mayland Drive, Suite 400, Richmond, VA 23233

Telephone: (804) 367-8500

EXPIRES ON
02-28-2022

NUMBER
0411001228

BOARD FOR ARCHITECTS, PROFESSIONAL ENGINEERS, LAND SURVEYORS, CERTIFIED INTERIOR DESIGNERS
AND LANDSCAPE ARCHITECTS
BUSINESS ENTITY BRANCH OFFICE REGISTRATION

PROFESSIONS-ENG



WHITMAN, REQUARDT AND ASSOCIATES LLP
100 5TH ST STE L2000
BRISTOL, TN 37620



Mary Broz-Vaughan
Mary Broz-Vaughan, Director

Status can be verified at <http://www.dpor.virginia.gov>

(SEE REVERSE SIDE FOR PRIVILEGES AND INSTRUCTIONS)

DPOR-LIC (02/2017)

COMMONWEALTH of VIRGINIA

Department of Professional and Occupational Regulation

9960 Mayland Drive, Suite 400, Richmond, VA 23233

Telephone: (804) 367-8500

EXPIRES ON

02-28-2022

NUMBER

0411001412

BOARD FOR ARCHITECTS, PROFESSIONAL ENGINEERS, LAND SURVEYORS, CERTIFIED INTERIOR DESIGNERS AND LANDSCAPE ARCHITECTS
BUSINESS ENTITY BRANCH OFFICE REGISTRATION

PROFESSIONS: ENG



WHITMAN, REQUARDT AND ASSOCIATES LLP
300 SUMMERS ST
STE 810
CHARLESTON, WV 25301



Mary Broz-Vaughan
Mary Broz-Vaughan, Director

Status can be verified at <http://www.dpor.virginia.gov>

(SEE REVERSE SIDE FOR PRIVILEGES AND INSTRUCTIONS)

DPOR-LIC (02/2017)

(DETACH HERE)



COMMONWEALTH of VIRGINIA
Department of Professional and Occupational Regulation

BOARD FOR AP/ELSC/DLA
BUSINESS ENTITY BRANCH OFFICE REGISTRATION
NUMBER: 0411001412 EXPIRES: 02-28-2022
PROFESSIONS: ENG
WHITMAN, REQUARDT AND ASSOCIATES LLP
300 SUMMERS ST
STE 810
CHARLESTON, WV 25301



(FOLD)

Status can be verified at <http://www.dpor.virginia.gov>

DPOR-PC (02/2017)

REGISTRATION 1/17/2016 6:58:08 AM

COMMONWEALTH of VIRGINIA

Department of Professional and Occupational Regulation

9960 Mayland Drive, Suite 400, Richmond, VA 23233

Telephone: (804) 367-8500

EXPIRES ON
02-28-2022

NUMBER
0411000134

BOARD FOR ARCHITECTS, PROFESSIONAL ENGINEERS, LAND SURVEYORS, CERTIFIED INTERIOR DESIGNERS
AND LANDSCAPE ARCHITECTS
BUSINESS ENTITY BRANCH OFFICE REGISTRATION

PROFESSIONS: ENG



WHITMAN REQUARDT AND ASSOCIATES
12700 FAIR LAKES CIR
#300
FAIRFAX, VA 22033



Mary Broz-Vaughan
Mary Broz-Vaughan, Director

Status can be verified at <http://www.dpor.virginia.gov>

(SEE REVERSE SIDE FOR PRIVILEGES AND INSTRUCTIONS)

DPOR-LIC (02/2017)

COMMONWEALTH of VIRGINIA

Department of Professional and Occupational Regulation

9960 Mayland Drive, Suite 400, Richmond, VA 23233

Telephone: (804) 367-8500

EXPIRES ON

02-28-2022

NUMBER

0411000861

BOARD FOR ARCHITECTS, PROFESSIONAL ENGINEERS, LAND SURVEYORS, CERTIFIED INTERIOR DESIGNERS
AND LANDSCAPE ARCHITECTS
BUSINESS ENTITY BRANCH OFFICE REGISTRATION

PROFESSIONS: ENG



WHITMAN, REQUARDT AND ASSOCIATES LLP
1320 CENTRAL PARK BLVD
SUITE 224
FREDERICKSBURG, VA 22401



Mary Broz-Vaughan
Mary Broz-Vaughan, Director

Status can be verified at <http://www.dpor.virginia.gov>

(SEE REVERSE SIDE FOR PRIVILEGES AND INSTRUCTIONS)

DPOR-LIC (02/2017)

(DETACH HERE)



COMMONWEALTH of VIRGINIA
Department of Professional and Occupational Regulation

BOARD FOR APESCIDLA
BUSINESS ENTITY BRANCH OFFICE REGISTRATION
NUMBER: 0411000861 EXPIRES: 02-28-2022
PROFESSIONS: ENG
WHITMAN, REQUARDT AND ASSOCIATES LLP
1320 CENTRAL PARK BLVD
SUITE 224
FREDERICKSBURG, VA 22401



(FOLD)

VOID

Status can be verified at <http://www.dpor.virginia.gov>

DPOR-PC (02/2017)

COMMONWEALTH of VIRGINIA

Department of Professional and Occupational Regulation

9960 Mayland Drive, Suite 400, Richmond, VA 23233

Telephone: (804) 367-8500

EXPIRES ON

02-28-2022

NUMBER

0411000774

BOARD FOR ARCHITECTS, PROFESSIONAL ENGINEERS, LAND SURVEYORS, CERTIFIED INTERIOR DESIGNERS
AND LANDSCAPE ARCHITECTS
BUSINESS ENTITY BRANCH OFFICE REGISTRATION

PROFESSIONS: ENG



WHITMAN REQUARDT AND ASSOCIATES LLP
1705 ENTERPRISE DR STE 100
LYNCHBURG, VA 24502



Mary Broz-Vaughan
Mary Broz-Vaughan, Director

Status can be verified at <http://www.dpor.virginia.gov>

(SEE REVERSE SIDE FOR PRIVILEGES AND INSTRUCTIONS)

DPOR-LIC (02/2017)

(DETACH HERE)



COMMONWEALTH of VIRGINIA
Department of Professional and Occupational Regulation

BOARD FOR APESCIDLA
BUSINESS ENTITY BRANCH OFFICE REGISTRATION
NUMBER: 0411000774 EXPIRES: 02-28-2022
PROFESSIONS: ENG
WHITMAN REQUARDT AND ASSOCIATES LLP
1705 ENTERPRISE DR STE 100
LYNCHBURG, VA 24502



(FOLD)

Status can be verified at <http://www.dpor.virginia.gov>

DPOR-PC (02/2017)

PATENTS 6,187,795 6,540,149

COMMONWEALTH of VIRGINIA

Department of Professional and Occupational Regulation

9960 Mayland Drive, Suite 400, Richmond, VA 23233

Telephone: (804) 367-8500

EXPIRES ON

02-28-2022

NUMBER

0411000244

BOARD FOR ARCHITECTS, PROFESSIONAL ENGINEERS, LAND SURVEYORS, CERTIFIED INTERIOR DESIGNERS AND LANDSCAPE ARCHITECTS
BUSINESS ENTITY BRANCH OFFICE REGISTRATION

PROFESSIONS: ENG



WHITMAN REQUARDT & ASSOCIATES LLP
11870 MERCHANTS WALK STE 100
NEWPORT NEWS, VA 23606



Mary Broz-Vaughan
Mary Broz-Vaughan, Director

Status can be verified at <http://www.dpor.virginia.gov>

(SEE REVERSE SIDE FOR PRIVILEGES AND INSTRUCTIONS)

DPOR-LIC (02/2017)

(DETACH HERE)



COMMONWEALTH of VIRGINIA
Department of Professional and Occupational Regulation

BOARD FOR APPLSCIDLA
BUSINESS ENTITY BRANCH OFFICE REGISTRATION
NUMBER: 0411000244 EXPIRES: 02-28-2022
PROFESSIONS: ENG
WHITMAN REQUARDT & ASSOCIATES LLP
11870 MERCHANTS WALK STE 100
NEWPORT NEWS, VA 23606



(FOLD)

Status can be verified at <http://www.dpor.virginia.gov>

DPOR-PC (02/2017)

PATENTS 5,197,765 5/26/19

COMMONWEALTH of VIRGINIA

Department of Professional and Occupational Regulation

9960 Mayland Drive, Suite 400, Richmond, VA 23233

Telephone: (804) 367-8500

EXPIRES ON
02-28-2022

NUMBER
0411000830

BOARD FOR ARCHITECTS, PROFESSIONAL ENGINEERS, LAND SURVEYORS, CERTIFIED INTERIOR DESIGNERS
AND LANDSCAPE ARCHITECTS
BUSINESS ENTITY BRANCH OFFICE REGISTRATION

PROFESSIONS: ENG



WHITMAN, REQUARDT AND ASSOCIATES LLP
2009 MACKENZIE WAY STE 240
CRANBERRY TOWNSHIP, PA 16066



Mary Broz-Vaughan
Mary Broz-Vaughan, Director

Status can be verified at <http://www.dpor.virginia.gov>

(SEE REVERSE SIDE FOR PRIVILEGES AND INSTRUCTIONS)

DPOR-LIC (02/2017)

(DETACH HERE)

DPOR COMMONWEALTH of VIRGINIA
Department of Professional and Occupational Regulation

BOARD FOR APESCIDLA
BUSINESS ENTITY BRANCH OFFICE REGISTRATION
NUMBER: 0411000830 EXPIRES: 02-28-2022
PROFESSIONS: ENG
WHITMAN, REQUARDT AND ASSOCIATES LLP
2009 MACKENZIE WAY STE 240
CRANBERRY TOWNSHIP, PA 16066



(FOLD)

Status can be verified at <http://www.dpor.virginia.gov>

DPOR-PC (02/2017)

COMMONWEALTH of VIRGINIA

Department of Professional and Occupational Regulation
9960 Mayland Drive, Suite 400, Richmond, VA 23233
Telephone: (804) 367-8500

EXPIRES ON
02-28-2022

NUMBER
0411001602

BOARD FOR ARCHITECTS, PROFESSIONAL ENGINEERS, LAND SURVEYORS, CERTIFIED INTERIOR DESIGNERS
AND LANDSCAPE ARCHITECTS
BUSINESS ENTITY BRANCH OFFICE REGISTRATION

PROFESSIONS: ENG



WHITMAN, REQUARDT AND ASSOCIATES LLP
1201 EDWARDS MILL RD
STE 320
RALEIGH, NC 27607



Mary Broz-Vaughan
Mary Broz-Vaughan, Director

Status can be verified at <http://www.dpor.virginia.gov>

(SEE REVERSE SIDE FOR PRIVILEGES AND INSTRUCTIONS)

DPOR-LIC (02/2017)

(DETACH HERE)

DPOR COMMONWEALTH of VIRGINIA
Department of Professional and Occupational Regulation

BOARD FOR APELSCIDLA
BUSINESS ENTITY BRANCH OFFICE REGISTRATION
NUMBER: 0411001602 EXPIRES: 02-28-2022
PROFESSIONS: ENG
WHITMAN, REQUARDT AND ASSOCIATES LLP
1201 EDWARDS MILL RD
STE 320
RALEIGH, NC 27607



(FOLD)

Status can be verified at <http://www.dpor.virginia.gov>

DPOR-PC (02/2017)

COMMONWEALTH of VIRGINIA

Department of Professional and Occupational Regulation
9960 Mayland Drive, Suite 400, Richmond, VA 23233
Telephone: (804) 367-8500

EXPIRES ON
02-28-2022

NUMBER
0411000908

BOARD FOR ARCHITECTS, PROFESSIONAL ENGINEERS, LAND SURVEYORS, CERTIFIED INTERIOR DESIGNERS
AND LANDSCAPE ARCHITECTS
BUSINESS ENTITY BRANCH OFFICE REGISTRATION

PROFESSIONS: ENG



WHITMAN, REQUARDT AND ASSOCIATES LLP
5701 CLEVELAND STREET
SUITE 620
VIRGINIA BEACH, VA 23462



Mary Broz-Vaughan
Mary Broz-Vaughan, Director

Status can be verified at <http://www.dpor.virginia.gov>

(SEE REVERSE SIDE FOR PRIVILEGES AND INSTRUCTIONS)

DPOR-LIC (02/2017)

(DETACH HERE)



COMMONWEALTH of VIRGINIA
Department of Professional and Occupational Regulation

BOARD FOR AP/ELSC/DLA
BUSINESS ENTITY BRANCH OFFICE REGISTRATION
NUMBER: 0411000908 EXPIRES: 02-28-2022
PROFESSIONS: ENG
WHITMAN, REQUARDT AND ASSOCIATES LLP
5701 CLEVELAND STREET
SUITE 620
VIRGINIA BEACH, VA 23462



(FOLD)

Status can be verified at <http://www.dpor.virginia.gov>

DPOR-PC (02/2017)

PERMITS 5/17/2015 5:04:58

COMMONWEALTH of VIRGINIA

Department of Professional and Occupational Regulation
9960 Mayland Drive, Suite 400, Richmond, VA 23233
Telephone: (804) 367-8500

EXPIRES ON
12-31-2021

NUMBER
0407002804

BOARD FOR ARCHITECTS, PROFESSIONAL ENGINEERS, LAND SURVEYORS, CERTIFIED INTERIOR DESIGNERS
AND LANDSCAPE ARCHITECTS
BUSINESS ENTITY REGISTRATION

PROFESSIONS: ENG



ATHAVALLE, LYSTAD AND ASSOCIATES INC
8180 GREENSBORO DRIVE
#550
MCLEAN, VA 22102



Mark Eric Vaughan
Mark Eric Vaughan, Director

Status can be verified at <http://www.dpor.virginia.gov>

(SEE REVERSE SIDE FOR PRIVILEGES AND INSTRUCTIONS)

DPOR-LIC (02/2017)

(DETACH HERE)

DPOR COMMONWEALTH of VIRGINIA
Department of Professional and Occupational Regulation

BOARD FOR APELSCIDLA
BUSINESS ENTITY REGISTRATION
NUMBER: 0407002804 EXPIRES: 12-31-2021
PROFESSIONS: ENG
ATHAVALLE, LYSTAD AND ASSOCIATES INC
8180 GREENSBORO DRIVE
#550
MCLEAN, VA 22102



(FOLD)

Status can be verified at <http://www.dpor.virginia.gov>

DPOR-PC (02/2017)

COMMONWEALTH of VIRGINIA

Department of Professional and Occupational Regulation

9960 Mayland Drive, Suite 400, Richmond, VA 23233

Telephone: (804) 367-8500

EXPIRES ON
12-31-2021

NUMBER
0407005432

BOARD FOR ARCHITECTS, PROFESSIONAL ENGINEERS, LAND SURVEYORS, CERTIFIED INTERIOR DESIGNERS
AND LANDSCAPE ARCHITECTS
BUSINESS ENTITY REGISTRATION

PROFESSIONS: LS



H & B SURVEYING & MAPPING LLC
614 MOOREFIELD PARK DR
RICHMOND, VA 23236



Mary Broz-Vaughan
Mary Broz-Vaughan, Director

Status can be verified at <http://www.dpor.virginia.gov>

(SEE REVERSE SIDE FOR PRIVILEGES AND INSTRUCTIONS)

DPOR-LIC (02/2017)

COMMONWEALTH of VIRGINIA

Department of Professional and Occupational Regulation

9960 Mayland Drive, Suite 400, Richmond, VA 23233

Telephone: (804) 367-8500

EXPIRES ON
12-31-2022

NUMBER
0226007129

REAL ESTATE BOARD - FIRM LICENSE

POST IN A CONSPICUOUS PLACE

THIS LICENSE TO BE IN CUSTODY AND CONTROL OF PRINCIPAL BROKER



KDR REAL ESTATE SERVICES INC
2500 GRENOBLE RD
RICHMOND, VA 23294



Mary Brock-Veddyhan
Mary Brock-Veddyhan, Director

Status can be verified at <http://www.dpor.virginia.gov>

(SEE REVERSE SIDE FOR PRIVILEGES AND INSTRUCTIONS)

DPOR-LIC (02/2017)

COMMONWEALTH of VIRGINIA

Department of Professional and Occupational Regulation

9960 Mayland Drive, Suite 400, Richmond, VA 23233

Telephone: (804) 367-8500

EXPIRES ON

02-28-2022

NUMBER

0411001489

BOARD FOR ARCHITECTS, PROFESSIONAL ENGINEERS, LAND SURVEYORS, CERTIFIED INTERIOR DESIGNERS AND LANDSCAPE ARCHITECTS
BUSINESS ENTITY BRANCH OFFICE REGISTRATION

PROFESSIONS: LS, ENG



CENTURY ENGINEERING, INC
CENTURY ENGINEERING INC. A MARYLAND BASED CORPORATION
114 E CARY ST STE 200
RICHMOND, VA 23219



Mary Broz-Vaughan
Mary Broz-Vaughan, Director

Status can be verified at <http://www.dpor.virginia.gov>

(SEE REVERSE SIDE FOR PRIVILEGES AND INSTRUCTIONS)

DPOR-LIC (02/2017)

(DETACH HERE)

DPOR COMMONWEALTH of VIRGINIA
Department of Professional and Occupational Regulation

BOARD FOR AP/LS/CID/LA
BUSINESS ENTITY BRANCH OFFICE REGISTRATION
NUMBER: 0411001489 EXPIRES: 02-28-2022
PROFESSIONS: LS, ENG
CENTURY ENGINEERING, INC
CENTURY ENGINEERING INC. A MARYLAND BASED CORPORATION
114 E CARY ST STE 200
RICHMOND, VA 23219



(FOLD)

Status can be verified at <http://www.dpor.virginia.gov>

DPOR-PC (02/2017)

PATENTS 5,197,705 5,240,159

COMMONWEALTH of VIRGINIA

Department of Professional and Occupational Regulation

9960 Mayland Drive, Suite 400, Richmond, VA 23233

Telephone: (804) 367-8500

EXPIRES ON

12-31-2021

NUMBER

0402041295

BOARD FOR ARCHITECTS, PROFESSIONAL ENGINEERS, LAND SURVEYORS, CERTIFIED INTERIOR DESIGNERS
AND LANDSCAPE ARCHITECTS
PROFESSIONAL ENGINEER LICENSE



MICHAEL WILLIAM SAUNDERS
4500 LITCHFIELD DRIVE
CHESTERFIELD, VA 23832



Mary Broz-Vaughan
Mary Broz-Vaughan, Director

Status can be verified at <http://www.dpor.virginia.gov>

(SEE REVERSE SIDE FOR PRIVILEGES AND INSTRUCTIONS)

DPOR-LIC (02/2017)

COMMONWEALTH of VIRGINIA

Department of Professional and Occupational Regulation

9960 Mayland Drive, Suite 400, Richmond, VA 23233

Telephone: (804) 367-8500

EXPIRES ON

01-31-2022

NUMBER

0402033974

BOARD FOR ARCHITECTS, PROFESSIONAL ENGINEERS, LAND SURVEYORS, CERTIFIED INTERIOR DESIGNERS
AND LANDSCAPE ARCHITECTS
PROFESSIONAL ENGINEER LICENSE



JEREMY SCHLUSSEL
9105 CARRINGTON HILLS CT
GLEN ALLEN, VA 23060



Mary Broz-Vaughan
Mary Broz-Vaughan, Director

Status can be verified at <http://www.dpor.virginia.gov>

(SEE REVERSE SIDE FOR PRIVILEGES AND INSTRUCTIONS)

DPOR-LIC (02/2017)

(DETACH HERE)



COMMONWEALTH of VIRGINIA
Department of Professional and Occupational Regulation

BOARD FOR APELSCIDLA
PROFESSIONAL ENGINEER LICENSE
NUMBER: 0402033974 EXPIRES: 01-31-2022

JEREMY SCHLUSSEL
9105 CARRINGTON HILLS CT
GLEN ALLEN, VA 23060



(FOLD)

Status can be verified at <http://www.dpor.virginia.gov>

DPOR-PC (02/2017)

PATENTS 5,197,706 5/24/19

ATTACHMENT 3.3.1
KEY PERSONNEL RESUME FORM

Brief Resume of Key Personnel anticipated for the Project.
a. Name & Title: Ryan Gorman, PE, DBIA Vice President, Alternative Contracting
b. Project Assignment: Design-Build Project Manager
c. Name of the Firm with which you are employed at the time of submitting SOQ.: Corman Kokosing Construction Company
d. Employment History: With this Firm <u>24</u> Years With Other Firms <u>1</u> Years Please list chronologically (most recent first) your employment history, position, general responsibilities, and duration of employment for the last fifteen (15) years. (NOTE: If you have less than 15 years of employment history, please list the history for those years you have worked. Project specific experience shall be included in Section (g) below): Corman Kokosing Construction Company <i>Start Date: 2016 End Date: Present Position: Vice President, Alternative Contracting</i> Manages design-build projects from procurement to final execution. Served as design-build integrator on two VDOT design-build projects where he streamlined integration with design and construction teams. <i>Start Date: 2015 End Date: 2016 Position: Design-Build Manager</i> Involved on an executive level on design-build procurements and projects. <i>Start Date: 2012 End Date: 2015 Position: Business Development Manager/Sr. Estimator</i> Managed Design-Build, Estimating, and Marketing Departments in Corman Kokosing's office near Richmond, VA. <i>Start Date: 1996 End Date: 2012 Position: Proj. Engineer/Superintendent/Proj. Manager/Operations Manager</i> Continuous progression of roles/responsibilities on road, bridge, and utility projects for VDOT, City of Richmond, and counties in Virginia. Responsibilities included managing onsite personnel, developing/reviewing QA/QC plans/programs, outlining project plans, inspecting/reviewing projects for safety/quality compliance and ensuring projects are completed on time.
e. Education: Name & Location of Institution(s)/Degree(s)/Year/Specialization: Clarkson University Potsdam, NY B.S. 1995 Civil Engineering Virginia Tech Blacksburg, VA 2001 Transportation Construction Management, Leadership Training
f. Active Registration: Year First Registered/ Discipline/VA Registration #: 2002 Registered Professional Engineer VA Registration #0402033522; 2006 Virginia DEQ Responsible Land Disturber #RLD12750; DBIA Certification
g. Document the extent and depth of your experience and qualifications relevant to the Project. 1. <i>Note your role, responsibility, and specific job duties for each project, not those of the firm.</i> 2. <i>Note whether experience is with current firm or with other firm.</i> 3. <i>Provide beginning and end dates for each project; projects older than fifteen (15) years will not be considered for evaluation.</i> (List only three (3) relevant projects* for which you have performed a similar function. If additional projects are shown in excess of three (3), the SOQ may be rendered non-responsive. In any case, only the first three (3) projects listed will be evaluated.)
ROUTE 1 TIE-IN TO WOODROW WILSON BRIDGE URBAN DECK VA-4, ALEXANDRIA, VA \$62.7M VDOT Name of Firm: Corman Kokosing Construction Company Project Role: Project Manager <i>Start Date: April 2003 End Date: April 2008</i> Specific Responsibilities: Project Manager. Ryan oversaw construction from start up to close out, managed the project team, equipment and material procurement, managed design completion/review (formwork, access platforms, support of excavation, utility support systems, temporary bridges, sound walls, VE proposals, erection drawings) and ensured timely/accurate completion of office and project engineering requirements, as well as technical supervision of field operations, established objectives/goals, work plans, budgets and resources, procured/coordinated subcontractors, developed project-specific safety program with project team, including training needs, monitored short/long range scheduling, conducted progress meetings, evaluated/minimized exposures/risks, mitigated issues, reviewed/approved deliverables, RFIs, change orders, administered contracts, and oversaw budget, safety, and quality compliance. He participated in public meetings and answered questions and was responsible in avoiding/resolving disputes. This two-phased, multi-level bridge, roadway demolition/reconstruction project included the new S. Washington Street Urban Deck Bridge over I-495, with its distinctive hour-glass design composed of three separate bridges, 280 ft. x 335 ft., built side-by-side and was constructed in four quadrants to maintain S. Washington Street traffic flow. There was 28,000 CY cast-in-place architecturally-finished structural concrete, 50 precast fascia panels on bridge, AASHTO girders and precast post and panel sound walls. Placed 40,000 CY Low Density Cementitious Fill on the approach leading up the bridge's abutment. Utility relocations included water mains, sewer lines, storm drains, CCTV, lighting and electrical facilities. Installed duct banks for Dominion to pull their lines through. Sewer upgrades included ½ mile of 42-in. and 300-ft. of 30-in. micro-tunnel. Installed decorative lights along new bridge and Washington Street. Eliminated an urban deck construction phase resulting in a cost savings. Ryan worked with designer to design-build a temporary low-density cementitious fill ramp to replace a proposed bridge for MOT for an environmentally-friendly approach, adjacent to wetlands, to exceed at a higher level. He worked with the sound wall producer to design-build the noise walls. But it was the solution to separate schedule dependence from other Woodrow Wilson Bridge projects that became the crowning achievement. The award-winning, two phase Virginia Advance Connector was constructed to the bridge by shifting the Capital Beltway, which allowed construction to commence on the north half nine months earlier making it independent of the other projects. Ryan planned/executed this traffic switch by closing the beltway to one lane at each direction. Coordination/collaborative teamwork proved conducive in performing work each weekend ahead of schedule with minimal public impact. Relevancy: <i>VDOT Design-Build Elements; Survey; Environmental Permits; Utility Relocations/</i>

Additions/Adjustments; Roadway Construction; Milling/Overlaying Existing Pavement; Bridge Demolition/Construction; Guardrail/Barrier; Signs/Sign Structures/Foundations; Traffic Signal; Overhead Sign Structures; ITS Components; Lighting; TMP/MOT; Pavement Markings; Storm Drainage; Stakeholder Coordination/Public Outreach; Project Management; Coordination with Adjacent Construction Projects

DESIGN-BUILD I-64 WIDENING EXITS 200-205, HENRICO/NEW KENT COUNTIES, VA | \$46.6M | VDOT

Name of Firm: Corman Kokosing Construction Company *Project Role:* Design/Construction Integrator | Deputy Design-Build Project Manager | *Start Date:* March 2017 *End Date:* December 2019

Specific Responsibilities: Design/Construction Integrator | Deputy Design-Build Project Manager. As DC/I, Ryan managed the designer and integrated the design-build process with the construction teams to ensure contract conformance, compiled final Released for Construction plans/specifications/final work packages, performed design quality/constructability reviews, held designer to the project schedule, coordinated design reviews with reviewing agencies, and was available to resolve any potential hazards. He ensured ROW, environmental permits, and utility relocations were completed timely, made engineering designs and evaluated for any project impacts, made/approved engineering decisions during construction, attended public meetings, had the authority to stop work and ensured safe, constructible, functional project delivery. As Deputy DBPM, Ryan assisted/ensured design, construction, quality management, contract administration and other contract required services, including procuring/furnishing materials, equipment, services and labor reasonably inferable from the contract timely. This project widened eastbound/westbound bridges to the inside and rehabilitated the deck. There was an extremely narrow space in the median when widening the bridges. Since there was not enough width between the widened bridges for cranes, foundations, piers, and girders, they were constructed from the middle out. We matched the existing pier type and geometry for an aesthetically-pleasing structure. There was power line work and phased fiber install for CCTV camera. Designed/constructed temporary sediment basins where they could remain for duration of earthwork and then could be removed or converted to a permanent stormwater management basin. MOT included lane closures at night. **Relevancy:** *VDOT Design-Build; Survey; Environmental Permits; Acquiring ROW; Utility Relocations/Additions/Adjustments; Roadway Construction; Milling/Overlaying Existing Pavement; Bridge Construction; Guardrail/Barrier; Signs/Sign Structures/Foundations; Overhead Sign Structures; ITS Components; Lighting; TMP/MOT; Pavement Markers/Markings; Storm Drainage; SWM Facilities, Design/Construction QA/QC; Stakeholder Coordination/Public Outreach; Project Management*

DESIGN-BUILD ROUTE 29 SOLUTIONS, ALBEMARLE COUNTY, VA | \$129M | VDOT

Name of Firm: Corman Kokosing Construction Company *Project Role:* Responsible Charge Engineer | Interim Design-Build Project Manager | Deputy Design-Build Project Manager
Start Date: January 2015 *End Date:* July 2017

Specific Responsibilities: Responsible Charge Engineer. Ryan was responsible for engineering decisions relating to the final work product. He worked with the design/construction teams to streamline integration, was in conformance with the contract, compiled final Released for Construction plans/specifications/final work packages, communicated regularly with the owner and acted on behalf of the design-builder. Ryan worked with the design and construction managers and ensured each designed element was constructible and met VDOT's needs. He oversaw coordinating design elements from a design/construction perspective and worked shoulder-to-shoulder with design manager in a co-located project office. Ryan made engineering designs and evaluated for any project impacts, was available to resolve potential hazards, made/approved engineering decisions during construction, had the authority to stop work and ensured safe, constructible, functional project delivery. He also attended public meetings and answered questions. Ryan was **Interim DBPM** during the design and utility relocation phase. As **Deputy DBPM** during construction, Ryan assisted/ensured design, construction, quality management, contract administration and other contract-required services, including procuring/furnishing materials, equipment, services and labor reasonably inferable from the contract timely. Route 29 project, which is a major regional corridor, included bridge design/construction. Rio Road Bridge was a single span overpass of the new Route 29 thru lanes constructed with concrete box beams and a cast-in-place deck on top. Structural engineering was via a design method that had never been constructed in Virginia. The abutments were integrally placed on top of the soldier pile retaining wall to minimize the bridge's footprint and allowed Route 29 traffic to remain open throughout construction. The bridge superstructure was designed to act as a strut to support the retaining walls horizontally while supporting truck/roadway traffic vertically. Bridge/retaining walls were built in the congested intersection without acquiring additional ROW in an extremely tight schedule of 103 days allowable thru traffic restriction on Rio Road. Working six days a week around the clock, this bridge and thru lanes were completed in 57 days and the intersection was reopened to traffic 46 days ahead of schedule. Constructed a bridge on Berkmar Drive, which is a 716 ft. long steel girder with a concrete deck, parapet and retaining walls, Virginia-style abutments, multi-column piers with caps, and steel superstructure. Installed a drainage system underneath a new bridge and electrical conduits running through the concrete bridge deck and along the retaining walls. There were utility relocations for Dominion, Verizon Century Link, Comcast, Columbia Gas, City of Charlottesville Gas. Installed 830 LF of 18 in. and 915 LF of 24 in. DIP water mains, including fire hydrants and water meters in a highly congested area. Maintained existing lanes, roadway detours, night closures. Project was completed ahead of schedule. **Relevancy:** *VDOT Design-Build; Survey; Environmental Permits; ROW acquisition for 60 parcels; Utility Relocations/Additions/Adjustments; Roadway Construction; Milling/Overlaying Existing Pavement; Bridge Demolition/Construction; Guardrail/Barrier; Signs/Sign Structures/Foundations; Traffic Signal Modifications; Overhead Sign Structures; ITS Components; Lighting; TMP/MOT; Pavement Markers/Markings; Rehabilitated/Replaced Storm Drainage; SWM Facilities, Design/Construction QA/QC; Stakeholder Coordination/Public Outreach; Project Management; Coordination with Adjacent Construction Projects*

* On-call contracts with multiple task orders (on multiple projects) may not be listed as a single project.

h. For Key Personnel required to be on-site full-time for the duration of construction, provide a current list of assignments, role, and the anticipated duration of each assignment.

ATTACHMENT 3.3.1

KEY PERSONNEL RESUME FORM

Brief Resume of Key Personnel anticipated for the Project.
a. Name & Title: Mike Saunders, PE Senior Vice President
b. Project Assignment: Quality Assurance Manager
c. Name of the Firm with which you are employed at the time of submitting SOQ.: Century Engineering, Inc. d/b/a NXL
d. Employment History: With this Firm <u>9</u> Years With Other Firms <u>10</u> Years Please list chronologically (most recent first) your employment history, position, general responsibilities, and duration of employment for the last fifteen (15) years. (NOTE: If you have less than 15 years of employment history, please list the history for those years you have worked. Project specific experience shall be included in Section (g) below): Century Engineering, Inc. d/b/a NXL <i>Start Date: 2011 End Date: Present Position: Senior Vice President</i> Mike manages and coordinates the workload of our in-house staff and subconsultants, including overseeing our Prime VDOT District-Wide Contracts. By being the central point of contact for all Virginia operations, he provides consistency and coordination across all assigned tasks. His primary focus is establishing regular communications with clients, as well as continuing to provide project review and Quality Assurance/Quality Control (QA/QC) management. Virginia Department of Transportation – Richmond District <i>Start Date: 2011 End Date: 2011 Position: Project Controls Engineer</i> Mike was responsible for coordinating constructability reviews to include developing pre-advertisement schedules and sequence of construction as well as for coordination of post award schedule reviews and district wide schedule impact analysis. Was also responsible for performing District-Wide Notice of Intent (NOI) and claims analysis. Assigned as the Responsible Charge Project Manager for various Design-Build Projects throughout the Richmond District. This assignment included serving on the selection panel in the procurement phase and serving as project manager of the construction phase. Responsibilities included attending weekly progress meetings and multiple design meetings, and ultimately served as the responsible charge engineer acting on behalf of the owner. <i>Start Date: 2007 End Date: 2011 Position: Area Construction Engineer</i> Mike was responsible for executing a six-year program to include managing construction/maintenance contracts safely, with quality, on time, and within budget; to include providing responsible charge supervision and technical guidance to Construction Managers and Inspectors. Supervised all phases of multi-operational roadway and structural construction projects to ensure all work was performed in accordance with project plans, specifications, and special provisions. Responsible for producing a three-year outlook manpower plan for VDOT and Consultant Inspectors needs on upcoming projects. Coordinated with the appropriate staff in the preparation and review of work orders, NOIs, and claims to validate the necessity of work and level of federal participation if the Federal Highway Administration is involved. Performed Responsible Charge duties on no plan projects, minimum plan projects, and full plan projects of varying complexity ranging up to multi-million-dollar contracts. Assisted the Fredericksburg District with the administration of a Regional Design-Build Bridge Replacement project. Duties included making responsible charge decisions and coordinating activities for projects that are in the Richmond District. Virginia Department of Transportation – Salem District <i>Start Date: 2005 End Date: 2007 Position: Construction Project Manager</i> Mike supervised all phases of multi-operational roadway and structural construction projects to ensure all work is performed in accordance with project plans, specifications, and special provisions. Supervised multiple construction inspectors' work and career development and resolve contractual disputes with contractors. Prepared and presented the project showings and preconstruction conferences, prepared and submitted work orders, and tracked project cost to assure projects remained within the designated budget, on multiple projects of varying complexity. Coordinated with the appropriate staff in the preparation and review of Work Orders, NOIs, and claims to validate the necessity of work.
e. Education: Name & Location of Institution(s)/Degree(s)/Year/Specialization: Virginia Polytechnic Institute and State University Blacksburg, VA B.S. 2001 Civil Engineering
f. Active Registration: Year First Registered/ Discipline/VA Registration #: 2005 Professional Engineer VA Registration #0402041295
g. Document the extent and depth of your experience and qualifications relevant to the Project. <ol style="list-style-type: none">1. <i>Note your role, responsibility, and specific job duties for each project, not those of the firm.</i>2. <i>Note whether experience is with current firm or with other firm.</i>3. <i>Provide beginning and end dates for each project; projects older than fifteen (15) years will not be considered for evaluation.</i> <p>(List only three (3) relevant projects* for which you have performed a similar function. If additional projects are shown in excess of three (3), the SOQ may be rendered non-responsive. In any case, only the first three (3) projects listed will be evaluated.)</p>

DESIGN-BUILD I-64 WIDENING EXIT 200-205 | HENRICO/NEW KENT COUNTIES, VA, \$46.6M | VDOT*Name of Firm:* NXL*Project Role:* Quality Assurance Manager*Start Date:* March 2017*End Date:* December 2019

Specific Responsibilities: Quality Assurance Manager. Mike was responsible for preparing the project’s QA/QC plan, as well as the oversight of the project’s QA procedures and plans. He was responsible for the performance and coordination of QA testing and inspection in accordance with VDOT’s Design-Build guidelines. Mike monitored contractor’s QC program and served as the liaison with the Department with respect to project compliance to ensure that IA/IV testing was being performed. He approved QC inspection, staffing assignments to the project, and the QC frequency testing plan before submission to VDOT. Mike handled the preparation, maintenance, and submission of associated project documentation including, diaries, EEO, materials notebook and documentation, as-built sketches, the approval of monthly pay packages, and the preparation/submission of final records. In addition, he managed the projects QA staff and ensured that sufficient staffing was enforced to help ensure compliance with the contract, plans, and specifications.

This project widened eastbound/westbound bridges to the inside and rehabilitated the deck. There was an extremely narrow space in the median when widening the bridges. Since there was not enough width between the widened bridges for cranes, foundations, piers, and girders, they were constructed from the middle out. We matched the existing pier type and geometry for an aesthetically-pleasing structure. There was power line work and phased fiber install for CCTV camera. Designed/constructed temporary sediment basins where they could remain for duration of earthwork and then could be removed or converted to a permanent stormwater management basin. MOT included lane closures at night.

Relevancy: *VDOT Design-Build; Survey; Environmental Permits; Acquiring ROW; Utility Relocations/Additions/Adjustments; Roadway Construction; Milling/Overlaying Existing Pavement; Bridge Construction; Guardrail/Barrier; Signs/Sign Structures/Foundations; Overhead Sign Structures; ITS Components (CCTV, Cameras, Fiber Optic Communications); Lighting; TMP/MOT; Pavement Markers/Markings; Storm Drainage; Stormwater Management Facilities, Design/Construction QA/QC; Stakeholder Coordination/Public Outreach; Project Management*

DESIGN-BUILD ROUTE 3 WIDENING | \$25M | VDOT*Name of Firm:* NXL*Project Role:* Quality Assurance Manager*Start Date:* May 2014*End Date:* May 2017

Specific Responsibilities: Quality Assurance Manager. Mike improved a 5.1-mile section of Route 3 from two lanes to a four-lane divided highway. He prepared the project’s QA/QC plan, as well as the oversight of the project’s QA procedures and plan. Mike was responsible for the performance and coordination of QA testing and inspection in accordance with VDOT’s Design-Build guidelines. He monitored the contractor’s QC program and served as the liaison with the Department with respect to project compliance to ensure that IA/IV testing was being performed. Mike approved QC inspection, staffing assignments to the project, and the QC frequency testing plan before submission to VDOT. He handled the preparation, maintenance, and submission of associated project documentation, including, but not limited to diaries, EEO, materials/notebook/documentation, as-built sketches, the approval of monthly pay packages, and the preparation/submission of final records. Mike managed the projects QA staff and ensured there was sufficient staffing to help ensure compliance with the contract, plans, and specifications.

Relevancy: *VDOT Design-Build; Survey; Environmental Permits; ROW; Utility Relocations/Additions/Adjustments; Roadway Construction; Milling/Overlaying and/or Building up of Existing Pavement; Guardrail/Barrier; Signs/Sign Structures/Foundations; TMP/MOT; Pavement Marking; Storm Drainage; SWM Facilities, Design/Construction QA/QC; Stakeholder Coordination/Public Outreach; Project Management; Coordination with Adjacent Projects*

DESIGN-BUILD VIRGINIA CAPITAL TRAIL: VARINA PHASE | VARINA, VA \$13.5M | VDOT*Name of Firm:* NXL*Project Role:* Quality Assurance Manager*Start Date:* February 2013*End Date:* September 2016

Specific Responsibilities: Quality Assurance Manager. Mike constructed approximately eight miles of trail that was 10-ft. wide and included a pedestrian bridge over VA 895 with safety fencing. He prepared the project’s QA/QC plan, as well as oversight of the project’s QA procedures. Responsible for the performance and coordination of QA testing and inspection in accordance with VDOT’s Design-Build guidelines. Mike monitored the contractor’s QC program and served as the liaison with the Department with respect to project compliance to ensure that IA/IV testing is being performed. He approved QC inspection, staffing assignments to the project, and the QC frequency testing plan before submission to VDOT. Mike handled the preparation, maintenance, and submission of associated project documentation to include diaries, EEO, materials/notebook/documentation, as-built sketches, the approval of monthly pay packages, and the preparation/submission of final records. He managed the projects QA staff and ensured that there was sufficient staffing to help ensure compliance with the contract, plans, and specifications.

Relevancy: *VDOT Design-Build; Survey; Environmental Permits; ROW; Utility Relocations/Additions/Adjustments; Roadway Construction; Milling/Overlaying and/or Building up of Existing Pavement; Bridge Construction; Guardrail/Barrier; Signs/Sign Structures/Foundations; TMP/MOT; Pavement Marking; Storm Drainage; SWM Facilities, Design/Construction QA/QC; Stakeholder Coordination/Public Outreach; Project Management; Coordination with Adjacent Projects*

* On-call contracts with multiple task orders (on multiple projects) may not be listed as a single project.

h. For Key Personnel required to be on-site full-time for the duration of construction, provide a current list of assignments, role, and the anticipated duration of each assignment.

ATTACHMENT 3.3.1

KEY PERSONNEL RESUME FORM

Brief Resume of Key Personnel anticipated for the Project.	
a. Name & Title:	Jeremy Schussel, PE Senior Vice President
b. Project Assignment:	Design Manager
c. Name of the Firm with which you are employed at the time of submitting SOQ.:	Whitman, Requardt & Associates, LLP
d. Employment History: With this Firm <u>19</u> Years With Other Firms <u>5</u> Years	
Please list chronologically (most recent first) your employment history, position, general responsibilities, and duration of employment for the last fifteen (15) years. (NOTE: If you have less than 15 years of employment history, please list the history for those years you have worked. Project specific experience shall be included in Section (g) below):	
Whitman, Requardt & Associates, LLP	
<i>Start Date:</i> June 2006	<i>End Date:</i> Ongoing
<i>Position:</i> Bridge Design Manager	
Jeremy is responsible for the management of the WRA Bridge Division in Virginia, where he oversees a staff of 12 on a wide variety of projects that range from bridge structure/superstructure replacements or major rehabilitations on interstate, primary, and secondary roads that cross over highways and waterways to emergency projects to studies delivered through Design-Bid, Design-Build, and Emergency Procurement. Since 2006, he has been the Project Manager of 3 Regional and 2 Statewide (including the current 2018-2022) On-Call VDOT Structure and Bridge contracts where he is responsible for multiple assignments proceeding concurrently throughout Virginia where he has been responsible for over 30 bridge, superstructure and/or deck replacements on primary, secondary, and/or interstates throughout Virginia that range in size from 20 ft. to well over 1,500 ft. He is responsible for the overall design of the project, including ensuring the design is in accordance with current codes and specifications, including QA/QC of the final deliverable. During Construction, he is responsible for shop drawing review and field support as necessary to address questions. In addition to the On-Call Contracts, Jeremy has been the Design Manager for Project Specific Projects such as Rte. 173 (Denbigh Blvd.) over I-64 & CSXT Bridge Replacement (Corman Kokosing is the Contractor) the Bridge Design Manager for 5 Design Build Projects for projects on/over I-64, I-81, and I-95, and the Bridge Design Manager for Project Specific Projects on Primary and Interstate Roadways throughout VA. These projects range in complexity from staged construction to replacement on new alignments and from structural steel to pre-stressed girders and range in costs to over \$50M. In addition, over 30 of the projects where he was/is Design Manager have been built by Corman Kokosing for a total over \$250M in total construction costs.	
Whitman, Requardt & Associates, LLP	
<i>Start Date:</i> May 2001	<i>End Date:</i> June 2006
<i>Position:</i> Bridge Project Engineer	
Responsible for designing a wide variety of projects from bridge replacement projects on primary and interstate roadways to feasibility reports for bridge structure options. Projects included structural steel, including hybrid steel designs, and pre-stressed concrete bridge structures and sub-structure design. As the Bridge Project Engineer, he worked on major interstate replacement projects, which widened the interstate and Design-Build projects.	
e. Education: Name & Location of Institution(s)/Degree(s)/Year/Specialization:	West Virginia University Morgantown, WV M.S. 1996 Civil Engineering – Structures Virginia Military Institute Lexington, VA B.S. 1994 Civil & Environmental Engineering VDOT Transportation Project Management Institute (TPMI) 2010 NHI #130055 Safety Inspection of In-Service Bridges
f. Active Registration: Year First Registered/ Discipline/VA Registration #:	2000 Professional Engineer Virginia #033974
g. Document the extent and depth of your experience and qualifications relevant to the Project.	
1. Note your role, responsibility, and specific job duties for each project, not those of the firm.	
2. Note whether experience is with current firm or with other firm.	
3. Provide beginning and end dates for each project; projects older than fifteen (15) years will not be considered for evaluation.	
(List only three (3) relevant projects* for which you have performed a similar function. If additional projects are shown in excess of three (3), the SOQ may be rendered non-responsive. In any case, only the first three (3) projects listed will be evaluated.)	
DESIGN-BUILD I-64 WIDENING EXIT 200 TO 205 HENRICO/NEW KENT COUNTIES, VA \$46.6 M VDOT	
<i>Name of Firm:</i> Whitman, Requardt & Associates, LLP	<i>Project Role:</i> Bridge Design Manager
<i>Start Date:</i> March 2017	<i>End Date:</i> December 2019
<i>Specific Responsibilities:</i> Bridge Design Manager for the Design-Build widening of the existing I-64 over the Chickahominy River bridge structure widening and deck replacement/rehabilitation of the existing 1960s bridge structure. The 264-ft. twin bridge structures were widened by 26 ft. for a final width of 58 ft face-to-face of parapet	

which allowed for a third lane plus wider shoulders to be added in the median to this highly congested area on I-64. As part of the project, the new superstructure used Type III AASHTO Girders to match the existing girders installed in the 1960's and to reduce the Dead Loads to not exceed the loading capacities of the existing sub-structure units, 120 pcf concrete was used for the deck and parapets. In addition, to reduce the Live Loads to the existing foundations to allow removal of the joints, PTFE bearings were used. To support the new sub-structure, deep foundations were used. Jeremy was responsible for the entire design, including, Design QA/QC, and construction support (shop drawing review, RFIs, Contractor submissions for field activities, field modifications), field design changes, including a field inspection to document the condition of the existing facility for rehabilitation prior to completion and the final QA/QC Inspection for acceptance. This project was built by Corman Kokosing Construction.

Relevancy: *VDOT Design-Build; Survey; Environmental Permits; Acquiring ROW; Utility Relocations/ Additions/ Adjustments; Roadway Construction; Milling/Overlaying Existing Pavement; Bridge Construction; Guardrail/Barrier; Signs/Sign Structures/Foundations; Overhead Sign Structures; ITS Components (CCTV, Cameras, Fiber Optic Communications); Lighting; TMP/MOT; Pavement Markers/Markings; Storm Drainage; Stormwater Management Facilities, Design/Construction QA/QC; Stakeholder Coordination/Public Outreach; Project Management*

I-95 OVER ROUTE 608 (REYMET ROAD) | CHESTERFIELD COUNTY, VA | Est. \$11M | VDOT

Name of Firm: Whitman, Requardt & Associates, LLP
S&B On-Call

Project Role: Design Manager (Completed under the
End Date: September 2020

Specific Responsibilities: **Design Manager under the S&B On-Call Contract** for the ABC superstructure replacement of the existing single span structural steel superstructure originally completed in 1958 as part of the Richmond-Petersburg Turnpike and widened in 1977 and 1990 to accommodate widening of I-95. The existing superstructure was replaced due to the Structurally Deficient (SD) condition of the concrete deck and sub-standard vertical clearances, which caused frequent impacts and emergency repairs. Completed an in-depth field evaluation (with material testing) and developed plans for a rapid superstructure replacement over eight weekends to reduce the impacts to the over 100,000 vpd along this corridor. The final plans detailed two potential sequence of construction options using prefabricated bridge units (PBUs) to accelerate the superstructure replacement. To accommodate replacement of the approach slab, stainless steel corbel brackets will be used to support prefabricated approach slab elements. All of the work will occur during long weekend closures where four lanes of traffic will be maintained at all times. The final details provide for a jointless superstructure and an increased vertical clearance from 14'-4" to 15'-0". This project is currently under construction advertisement. Jeremy was responsible for the entire design and construction support services.

Relevancy: *Bridge Superstructure Design, ABC Construction; Survey; Utility Relocations/Additions/Adjustments; Roadway Construction; Milling/Overlaying and/or Building up of Existing Pavement; Bridge Demolition/Construction; Guardrail/Barrier; TMP/MOT; Pavement Markers/Markings; Storm Drainage; Design/Construction QA/QC; Stakeholder Coordination/Public Outreach; Project Management*

5TH STREET AND 7TH STREET OVER LEIGH STREET | CITY OF RICHMOND, VA | \$2M | CITY OF RICHMOND DPW

Name of Firm: Whitman, Requardt & Associates, LLP
Start Date: June 2013

Project Role: Design Manager
End Date: August 2015

Specific Responsibilities: **Design Manager** for the two ABC superstructure replacements of load posted bridges in Richmond located around the Richmond Coliseum that were completed in 1970 and are along the major routes in/out of downtown for the on/off ramps to I-95. Due to the nature of the original construction with post-tensioned adjacent hollow-core slabs, all traffic was required to be detoured on city streets for the ABC superstructure replacement. The project required significant coordination with VDOT and City of Richmond for emergency response times north of I-95 and along the interstate. For the final design, the new superstructures were designed as post-tensioned hollow-core slabs with a composite deck to eliminate all joints which reduced long-term maintenance. During construction, the 5th Street Pier Cap, which was detailed to be rehabilitated, was found to be in significantly worse condition on the top of the cap after the adjacent hollow-core slabs were removed. This required an emergency design and construction of a new pier cap on the existing columns, the results of which did not delay project completion. Unique to this project was that existing utilities were supported in-place to eliminate significant delays in construction. The two superstructures were replaced in less than eight months and re-opened in time for the 2015 UCI Road World Championship Race. Project also included significant coordination with City of Richmond DPU (Water and Gas), Dominion Energy, and Verizon. This project was constructed by Corman Kokosing Construction. Jeremy was responsible for the complete design, including Design QA/QC, construction support (Shop Drawings, Review of Contractor Submissions, field modifications, RFIs, etc), and coordination with City DPU & DPW, all businesses, utilities, and other agencies impacted by this project.

Relevancy: *City of Richmond DPW, ABC Superstructure Replacement; Survey; Acquiring Environmental Permits; Utility Relocations/Additions/Adjustments; Roadway Construction; Milling/Overlaying and/or Building up of Existing Pavement; Bridge Demolition/Construction; Barrier; Traffic Signal Modifications; Lighting; TMP/MOT; Pavement Markers/Markings; Storm Drainage; Design/Construction QA/QC; Stakeholder Coordination/Public Outreach; Project Management; Coordination with Adjacent Active Construction Projects; Coordination with City of Richmond DPW & DPU (Gas, Water, City Electric), Dominion Energy, Communications (Verizon & City), Coordination with adjacent projects*

* On-call contracts with multiple task orders (on multiple projects) may not be listed as a single project.

h. For Key Personnel required to be on-site full-time for the duration of construction, provide a current list of assignments, role, and the anticipated duration of each assignment.

ATTACHMENT 3.3.1
KEY PERSONNEL RESUME FORM

Brief Resume of Key Personnel anticipated for the Project.
a. Name & Title: John “Jake” Leffler Project Manager
b. Project Assignment: Construction Manager
c. Name of the Firm with which you are employed at the time of submitting SOQ.: Corman Kokosing Construction Company
d. Employment History: With this Firm 11 Years With Other Firms 5 Years Please list chronologically (most recent first) your employment history, position, general responsibilities, and duration of employment for the last fifteen (15) years. (NOTE: If you have less than 15 years of employment history, please list the history for those years you have worked. Project specific experience shall be included in Section (g) below): Corman Kokosing Construction Company <i>Start Date: 2009 End Date: Present Position: Project Engineer/Sr. Project Engineer/Project Manager</i> Jake has been assigned to Design-Build/Design-Bid-Build bridge, roadway, and utility projects throughout Virginia as construction manager, construction QC manager, project manager, and project engineer. He manages project teams, schedule, budget, safety, and quality control, works with clients/engineers, attends onsite progress meetings, negotiates change orders, provides material procurement, coordinates subcontractors, oversees field crews, identifies issues, and performs troubleshooting with minimal cost/schedule impacts. Manhattan Construction Company <i>Start Date: 2005 End Date: 2009 Position: Project Engineer</i> Jake coordinated materials, labor, schedules, and methods to optimize construction on two vertical construction projects. He worked with subcontractors, clients, and architects to resolve issues timely/cost-effectively. Jake prepared, reviewed, and processed RFIs/submittals, submitted client billings, reviewed subcontractor payment applications, reviewed drawings for constructability/resolved conflicts, performed QC inspections and oversaw punch list operations.
e. Education: Name & Location of Institution(s)/Degree(s)/Year/Specialization: University of Virginia Charlottesville, VA BS 2005 Civil Engineering
f. Active Registration: Year First Registered/ Discipline/VA Registration #: 2009 VDOT Erosion & Sediment Control Contractor Certification VA Registration #1-05007 2009 VA DEQ Responsible Land Disturber VA Registration #RLD12161
g. Document the extent and depth of your experience and qualifications relevant to the Project. 1. <i>Note your role, responsibility, and specific job duties for each project, not those of the firm.</i> 2. <i>Note whether experience is with current firm or with other firm.</i> 3. <i>Provide beginning and end dates for each project; projects older than fifteen (15) years will not be considered for evaluation.</i> (List only three (3) relevant projects* for which you have performed a similar function. If additional projects are shown in excess of three (3), the SOQ may be rendered non-responsive. In any case, only the first three (3) projects listed will be evaluated.)
DESIGN-BUILD I-64 WIDENING EXITS 200-205, HENRICO & NEW KENT COUNTIES, VA 46.6M VDOT <i>Name of Firm: Corman Kokosing Construction Company Project Role: Construction Manager</i> <i>Start Date: March 2017 End Date: December 2019</i> Specific Responsibilities: Construction Manager. Jake supervised field operations, ensured construction was per drawings, maintained as-built documents, conducted preconstruction staff meetings establishing goals/responsibilities, evaluated safety exposures/risks, participated in developing the project-specific safety program, work plans, and Job Hazard Analyses, reviewed scope to identify safety training needs, reviewed Toolbox Talks, Take Fives, Morning Huddles, and Site Inspections weekly, conducted weekly safety inspections with project manager/project engineer, submitted weekly Safety Inspection Reports, coordinated labor, equipment, and subcontractors, schedules, oversaw quality control compliance and project close out. This project widened eastbound/westbound bridges to the inside and rehabilitated the deck. There was an extremely narrow space in the median when widening the bridges. Since there was not enough width between the widened bridges for cranes, foundations, piers, and girders, they were constructed from the middle out. We matched the existing pier type and geometry for an aesthetically-pleasing structure. There was power line work and phased fiber install for CCTV camera. Designed/constructed temporary sediment basins where they could remain for duration of earthwork and then could be removed or converted to a permanent stormwater management basin. MOT included lane closures at night. Relevancy: <i>VDOT Design-Build; Survey; Acquiring Environmental Permits; Acquiring ROW; Utility Relocations/Additions/Adjustments; Roadway Construction; Milling/Overlaying and/or Building up of Existing Pavement; Bridge Construction; Guardrail/Barrier; Signs/Sign Structures/Foundations; Overhead Sign Structures/other Traffic Control Measures; ITS Components, including CCTV, Cameras and Fiber Optic Communications; Lighting; TMP/MOT; Pavement Markers/Markings; Storm Drainage; Stormwater Management Facilities, Design/Construction QA/QC; Stakeholder Coordination/Public Outreach; Project Management</i>
DESIGN-BUILD ROUTE 29 SOLUTIONS, ALBEMARLE COUNTY, VA \$129M VDOT <i>Name of Firm: Corman Kokosing Construction Company Project Role: Segment Leader</i> <i>Start Date: January 2016 End Date: July 2017</i> Specific Responsibilities: Segment Leader. Jake managed construction from planning, sequencing, staffing, schedule, and cost. He held preparatory/preconstruction meetings, and coordinated daily with QA/QC staff, owner, and designers

to resolve conflicts as they arose. Jake managed QC activities and ensured materials used and work performed met the contract and approved for construction plans/specifications. He led a team of engineers to manage material/equipment procurement, scheduled/coordinated subcontractors, and ensured project was constructed safely, on schedule, on budget, and per contract. Jake held the Segment Leader role on the Rio Road Grade-Separated Intersection element from Jan. 2016 through its Fall 2016 completion, when he took on the same role for the Berkmar Dr. Extension element through July 2017. Route 29 project, which is a major regional corridor, included bridge design/construction. Rio Road Bridge was a single span overpass of the new Route 29 thru lanes constructed with concrete box beams and a cast-in-place deck on top. Structural engineering was via a design method that had never been constructed in Virginia. The abutments were integrally placed on top of the soldier pile retaining wall to minimize the bridge's footprint and allowed Route 29 traffic to remain open throughout construction. The bridge superstructure was designed to act as a strut to support the retaining walls horizontally while supporting truck/roadway traffic vertically. Bridge/retaining walls were built in the congested intersection without acquiring additional ROW in an extremely tight schedule of 103 days allowable thru traffic restriction on Rio Road. Working six days a week around the clock, this bridge and thru lanes were completed in 57 days and the intersection was reopened to traffic 46 days ahead of schedule. Constructed a bridge on Berkmar Drive, which is a 716-ft. long steel girder with a concrete deck, parapet and retaining walls, Virginia-style abutments, multi-column piers with caps, and steel superstructure. Installed a drainage system underneath a new bridge and electrical conduits running through the concrete bridge deck and along the retaining walls. There were utility relocations for Dominion, Verizon Century Link, Comcast, Columbia Gas, City of Charlottesville Gas. Installed 830 LF of 18-in. and 915 LF of 24-in. DIP water mains, including fire hydrants and water meters in a highly congested area. Maintained existing lanes, roadway detours, night closures. Project was completed ahead of schedule.

Relevancy: *VDOT Design-Build; Survey; Acquiring Environmental Permits; ROW acquisition for 60 parcels; Utility Relocations/Additions/Adjustments; Roadway Construction; Milling/Overlaying of Existing Pavement; Bridge Demolition/Construction; Guardrail/Barrier; Signs/Sign Structures/Foundations; Traffic Signal Modifications; Overhead Sign Structures; ITS Components, including CCTV, Cameras and Fiber Optic Communications; Lighting; TMP/MOT; Pavement Markers/Markings; Rehabilitated/Replaced Storm Drainage; Stormwater Management Facilities, Design/Construction QA/QC; Stakeholder Coordination/Public Outreach; Project Management; Coordination with Adjacent Active Construction Projects*

DESIGN-BUILD I-64 TO ROUTE 623 WIDENING & IMPROVEMENTS, SHORT PUMP, VA | \$34.7 M | VDOT

Name of Firm: Corman Kokosing Construction Company *Project Role:* Construction Manager/Construction QC Manager

Start Date: May 2014

End Date: December 2015

Specific Responsibilities: Construction Manager | Construction QC Manager. As CM, Jake managed construction, equipment and material procurement, work plans, budgets, and resources, coordinated subcontractors, monitored schedules, led progress meetings, minimized exposures/risks, mitigated issues, reviewed/approved deliverables, RFIs, and change orders, administered subcontractor contracts, oversaw budget, safety, and quality compliance, and ensured project was completed per contract. He coordinated issue resolutions, managed submittal procedures and material procurement, was a secondary contact for operations/procedures, and participated in design development/reviews. Original scope widened/replaced the bridge superstructure and widened/repared the existing substructure. The three-span bridges were in poor condition with the simple-span steel beams, including fatigue prone details, exhibiting significant section loss. Repair/replacement options were investigated; given the inefficient span arrangement of the current bridges and concerns about overloading the existing piers, a complete bridge replacement was chosen. Twin replacement bridges were designed for I-64. The new 130-ft. simple span pre-stressed concrete girder bridges replaced the three-span steel girder bridges using pre-stressed concrete Bulb T girders and a deck slab extension which provided VDOT with new, low maintenance structures accompanied by a 75-year design life at a lower cost than the rehabilitation option. Upgraded protection barrier at overpasses to increase motorist safety and provide increased collision protection to bridge substructure. Our stormwater management design reduced the linear foot distance of water quality swales and wetland impact, which minimized environmental impacts, construction costs, and long-term maintenance needs.

Relevancy: *VDOT Design-Build; Survey; Acquiring Environmental Permits;; Roadway Construction; Milling/Overlaying of Existing Pavement; Bridge Demolition/Construction; Guardrail/Barrier; Signs/Sign Structures/Foundations; Traffic Signal Modifications; Overhead Sign Structures/other Traffic Control Measures; ITS Components, including CCTV, Cameras and Fiber Optic Communications; Lighting; TMP/MOT; Pavement Markings; Storm Drainage; Stormwater Management Facilities, Design/Construction QA/QC; Stakeholder Coordination/Public Outreach; Project Management; Coordination with Adjacent Active Construction Projects*

* On-call contracts with multiple task orders (on multiple projects) may not be listed as a single project.

h. For Key Personnel required to be on-site full-time for the duration of construction, provide a current list of assignments, role, and the anticipated duration of each assignment.

ASSIGNMENT	ROLE	ANTICIPATED DURATION
Design-Build Bridge Replacement over Gambo Creek	Construction Manager	January 2020 – February 2021

ATTACHMENT 3.3.1

KEY PERSONNEL RESUME FORM

Brief Resume of Key Personnel anticipated for the Project.	
a.	Name & Title: Paul Martin Utility Coordinator
b.	Project Assignment: Lead Utility Coordination Manager
c.	Name of the Firm with which you are employed at the time of submitting SOQ.: Whitman, Requardt & Associates, LLP
d.	<p>Employment History: With this Firm <u>7</u> Years With Other Firms <u>25</u> Years</p> <p>Please list chronologically (most recent first) your employment history, position, general responsibilities, and duration of employment for the last fifteen (15) years. (NOTE: If you have less than 15 years of employment history, please list the history for those years you have worked. Project specific experience shall be included in Section (g) below):</p> <p>Whitman, Requardt & Associates, LLP <i>Start Date:</i> October 2013 <i>End Date:</i> Present <i>Position:</i> Utility Coordinator</p> <p>Performing utility coordination on a wide variety of road and bridge construction projects throughout Virginia. Identifying existing utilities at project sites. Working with utility company representatives to identify conflicts between existing utility facilities and planned construction and making arrangements to relocate those facilities or mitigate the conflicts through design modifications. Tracking relocation construction work. Reviewing and approving utility invoices. Providing utility clearance certifications. Keeping all appropriate project records. Performing project investigations and preparing scoping reports regarding utilities. Preparing Design-Build proposal sections regarding utilities.</p> <p>Schneider Electric (formerly Telvent North America, Inc.) <i>Start Date:</i> February 2009 <i>End Date:</i> October 2013 <i>Position:</i> Utility Coordinator</p> <p>Providing oversight and review for VDOT of the utility coordination work performed by the Concessionaires for the I-495 HOT Lanes and I-95 Express Lanes P3 Projects. Performing utility coordination duties in Virginia for VDOT as part of the GEC for the Woodrow Wilson Bridge Project. Performing utility coordination on several other projects within the scope of the VDOT MegaProjects Office including the Fairfax County Parkway. Identifying existing utilities at project sites. Working with utility company representatives to identify conflicts between existing utility facilities and planned construction and making arrangements to relocate those facilities or mitigate the conflicts through design modifications. Tracking relocation construction work. Reviewing and approving utility invoices. Providing utility clearance certifications. Keeping all appropriate project records. Performing project investigations and preparing scoping reports regarding utilities.</p> <p>Parsons Brinckerhoff Construction Services <i>Start Date:</i> July 2001 <i>End Date:</i> February 2009 <i>Position:</i> Lead Construction Engineer</p> <p>Served as the Resident Construction Engineer for the Woodrow Wilson Bridge Project soils improvement and initial fill project at the outer loop abutment of the new WWB for Maryland MSHA. Served as the Virginia Utility Coordinator for VDOT as part of the GEC for the Woodrow Wilson Bridge Project. Identifying existing utilities at project sites. Working with utility company representatives to identify conflicts between existing utility facilities and planned construction and making arrangements to relocate those facilities or mitigate the conflicts through design modifications. Tracking relocation construction work. Reviewing and approving utility invoices. Providing utility clearance certifications. Keeping all appropriate project records. Performing project investigations and preparing scoping reports regarding utilities.</p>
e.	Education: Name & Location of Institution(s)/Degree(s)/Year/Specialization: The Pennsylvania State University State College, PA B.S. 1988 Civil Engineering
f.	Active Registration: Year First Registered/ Discipline/VA Registration #: Not Applicable
g.	<p>Document the extent and depth of your experience and qualifications relevant to the Project.</p> <ol style="list-style-type: none"> 1. <i>Note your role, responsibility, and specific job duties for each project, not those of the firm.</i> 2. <i>Note whether experience is with current firm or with other firm.</i> 3. <i>Provide beginning and end dates for each project; projects older than fifteen (15) years will not be considered for evaluation.</i> <p>(List only three (3) relevant projects* for which you have performed a similar function. If additional projects are shown in excess of three (3), the SOQ may be rendered non-responsive. In any case, only the first three (3) projects listed will be evaluated.)</p> <p style="background-color: #0056b3; color: white; padding: 5px;">DESIGN-BUILD I-64 WIDENING EXIT 200 TO 205 HENRICO/NEW KENT COUNTIES, VA \$46.6M VDOT</p> <p><i>Name of Firm:</i> Whitman, Requardt & Associates, LLP <i>Project Role:</i> Lead Utility Coordination Manager <i>Start Date:</i> March 2017 <i>End Date:</i> December 2019</p>

Specific Responsibilities: **Lead Utility Coordination Manager** for VDOT Design-Build project for widening I-64 east of the Interchange with I-295. Widened eastbound/westbound bridges to the inside and rehabilitated the deck. Coordinating with out of plan utilities to identify existing facilities and clear conflicts. Utilities coordinated with include Virginia Natural Gas, Comcast, Cox Communications, Verizon, Summit IG, and Dominion Energy. Paul was responsible for WRA's coordination with all utility companies along I-64 in Henrico County and New Kent County, Virginia between mile markers 200 and 205. The existing utility facilities needed to be identified and have their locations verified. The existing facilities then needed to be checked against the construction plans and all conflicts identified. Relocation plans and estimates needed to be prepared and reviewed for accuracy and content. Relocation work schedules needed to be coordinated and tracked. Invoices needed to be reviewed and recommended for payments. Utility tracking reports needed to be prepared and submitted. VDOT RUMS records needed to be created and kept current. Investigations of utility facilities discovered or damaged during roadway construction needed to be investigated and repairs initiated. Participation in progress meetings was needed. Project records were kept. Utility clearance certification was provided.

Relevancy: *VDOT Design-Build; Survey; Environmental Permits; Acquiring ROW; Utility Relocations/Additions/Adjustments; Roadway Construction; Milling/Overlaying Existing Pavement; Bridge Construction; Guardrail/Barrier; Signs/Sign Structures/Foundations; Overhead Sign Structures; ITS Components (CCTV, Cameras, Fiber Optic Communications); Lighting; TMP/MOT; Pavement Markers/Markings; Storm Drainage; Stormwater Management Facilities, Design/Construction QA/QC; Stakeholder Coordination/Public Outreach; Project Management*

DESIGN-BUILD I-81 BRIDGES OVER ROUTE 11, NORFOLK SOUTHERN RAILROAD AND MIDDLE FORK HOLSTON RIVER | SMYTH COUNTY, VA | \$17.6M | VDOT

Name of Firm: Whitman, Requardt & Associates, LLP *Project Role:* Lead Utility Coordination Manager
Start Date: March 2019 *End Date:* 2021

Specific Responsibilities: **Lead Utility Coordination Manager** for this VDOT Design-Build project and involves replacement of I-81 bridges over Route 11, NS Railroad and Middle Fork Holston River for a total length of approximately 0.90 miles. Paul is responsible for WRA's coordination with all utility companies along I-81 for 0.9 miles at the Route 11, NS Railroad and Middle Fork Holston River Bridges. The existing utility facilities needed to be identified and have their locations verified. The existing facilities then needed to be checked against the construction plans and all conflicts identified. Relocation plans and estimates needed to be prepared and reviewed for accuracy and content. Relocation work schedules needed to be coordinated and tracked. Utility tracking reports needed to be prepared and submitted. VDOT RUMS records needed to be created and kept current. Investigations of utility facilities discovered or damaged during roadway construction needs to be investigated and repairs initiated. Project records are being kept. Utility clearance certification is to be provided.

Relevancy: *VDOT Design-Build; Survey; Acquiring Environmental Permits; Utility Relocations/Additions/Adjustments; Roadway Construction; Milling/Overlaying and/or Building up of Existing Pavement; Bridge Demolition/Construction; Guardrail/Barrier; Signs/Sign Structures/Foundations; TMP/MOT; Pavement Markers/Markings; Storm Drainage; Stormwater Management Facilities, Design/Construction QA/QC; Stakeholder Coordination/Public Outreach; Project Management*

DESIGN-BUILD I-95 SAFETY IMPROVEMENTS AT ROUTE 3 | FREDERICKSBURG, VA | \$18.7M | VDOT

Name of Firm: Whitman, Requardt & Associates, LLP *Project Role:* Lead Utility Coordination Manager
Start Date: September 2016 *End Date:* November 2018

Specific Responsibilities: **Lead Utility Coordination Manager** for VDOT Design-Build project for reconstructing portions of the I-95 Interchange with VA Route 3. Coordinating with out of plan utilities to identify existing facilities and clear conflicts. Utilities identified as being in conflict include Columbia Gas, Cox Communications, Verizon, Summit IG, and Uniti-Fiber. Paul was responsible for WRA's coordination with all utility companies along Northbound I-95 from Cowan Blvd. to Fall Hill Avenue in Fredericksburg. The existing utility facilities needed to be identified and have their locations verified. The existing facilities then needed to be checked against the construction plans and all conflicts identified. Relocation plans and estimates needed to be prepared and reviewed for accuracy and content. Relocation work schedules needed to be coordinated and tracked. Invoices needed to be reviewed and recommended for payments. Utility tracking reports needed to be prepared and submitted. VDOT RUMS records needed to be created and kept current. Investigations of utility facilities discovered or damaged during roadway construction needed to be investigated and repairs initiated. Participation in progress meetings was needed. Project records were kept. Utility clearance certification was provided.

Relevancy: *VDOT Design-Build; Survey; Acquiring ROW; Utility Relocations/Additions/Adjustments; Roadway Construction; Milling/Overlaying and/or Building up of Existing Pavement; Signs/Sign Structures/Foundations; Traffic Signal Modifications; Overhead Sign Structures/other Traffic Control Measures; ITS Components, including CCTV, Cameras and Fiber Optic Communications; Lighting; TMP/MOT; Pavement Markers/Markings; Storm Drainage; Stormwater Management Facilities, Design/Construction QA/QC; Stakeholder Coordination/Public Outreach; Project Management*

* On-call contracts with multiple task orders (on multiple projects) may not be listed as a single project.

h. For Key Personnel required to be on-site full-time for the duration of construction, provide a current list of assignments, role, and the anticipated duration of each assignment.

ATTACHMENT 3.4.1(a)
LEAD CONTRACTOR - WORK HISTORY FORM
(LIMIT 1 PAGE PER PROJECT)

a. Project Name & Location	b. Name of the prime design consulting firm responsible for the overall project design.	c. Contact information of the Client or Owner and their Project Manager who can verify Firm's responsibilities.	d. Contract Completion Date (Original)	e. Contract Completion Date (Actual or Estimated)	f. Contract Value (in thousands)		g. Dollar Value of Work Performed by the Firm identified as the Lead Contractor for this procurement.(in thousands)
					Original Contract Value	Final or Estimated Contract Value	
Name: Design-Build Route 29 Solutions Rio Road Grade Separated Intersection Location: Albemarle County, Virginia	Name: RK&K	Name of Client/ Owner: VDOT Phone: 540-292-3802 Project Manager: David Covington, PE Phone: 434-302-3048 Email: David.Covington@VDOT.Virginia.gov	10/2017	7/2017	\$40,000	\$46,336 (due to incentive payments for completing ahead of schedule)	\$46,336



h. Narrative describing the Work Performed by the Firm identified as the Lead Contractor for this procurement. If the Offeror chooses to submit work completed by an affiliated or subsidiary company of the Lead Contractor, identify the full legal name of the affiliate or subsidiary and the role they will have on this Project, so the relevancy of that work can be considered accordingly. The Work History Form shall include only one singular project. Projects/contracts with multiple phases, segments, elements (projects), and/or contracts shall not be considered a single project. Projects/contracts with multiple phases, segments, elements (projects), and/or contracts shall not be claimed as a single project on this form. If the Offeror chooses to submit work performed as a Joint Venture or Partnership, identify how the Joint Venture or Partnership was structured and provide a description of the portion of the work performed only by the Offeror's firm.

<p align="center">RELEVANCY</p> <ul style="list-style-type: none"> VDOT Design-Build Survey Environmental Permitting Right of Way Utility Relocations/Additions/Adjustments Roadway Construction Milling/Overlying of Existing Pavement Bridge Demolition/Construction Guardrail/Barrier Signs/Sign Structures/Foundations Traffic Signal Modifications Overhead Sign Structures ITS Components including CCTV, and Fiber Optic Communications Infrastructure Lighting TMP/MOT Pavement Markers/Markings Storm Drainage Stormwater Management Facilities QA/QC for Design and Construction Stakeholder Coordination/Public Outreach Coordination with Adjacent Construction Projects 	<p align="center">TEAM MEMBERS</p> <ul style="list-style-type: none"> ✓ Proposed DBPM Ryan Gorman was the Responsible Charge Engineer, Interim DBPM and Deputy DBPM ✓ Proposed CM Jake Leffler was a Segment Leader ✓ Proposed Senior Project Engineer Jonathan Smith was Project Engineer ✓ Proposed Superintendent Chico Georgopoulos was Superintendent 	<p align="center"><i>Photo courtesy of Enrique Shore for Lane</i></p>  <p align="center">Rio Road over Route 29</p> <p>Corman Kokosing Role Brief Project Description Corman Kokosing, a LANE/Corman Joint Venture partner as the design builder, was responsible for design/construction and constructed the bridges, retaining walls, and road work. This project provides a grade separation to move traffic more smoothly through the Route 29 and Rio Road intersection, one of the most congested intersections of the corridor.</p> <p>Accelerated Bridge Construction (ABC) Rio Road Bridge was a single span overpass of the new Route 29 through lanes constructed with concrete box beams and a cast-in-place deck on top which is three times wider than long and was poured in three placements. Construction was fast-tracked with most of the substructure constructed under traffic. The abutments were supported on the same pile that supported the retaining wall. The bridge beams also acted as a strut to support the retaining wall and eliminated the need for retention tiebacks. The Rio Road crossover was closed for 57 days (103 days were allowed) to finalize construction of the bridge/retaining walls across Route 29, thru lanes, and new modified SPUI. Relocated thru traffic on Route 29 to the outer lanes and temporary pavement while crews worked <i>Around the Clock</i> under an aggressive schedule in the median area to remove 30 inches of asphalt and excavated 60,000 CY of dirt while setting 47 concrete beams for the bridge deck. As the earth was removed, supportive sheathing was placed between the installed steel pilings. Work included excavation, installing a drainage system underneath the bridge compacting gravel as the base layer for the paved through lanes, and electrical conduits running through the concrete bridge deck and along the retaining walls. Working six days a week around the clock, crews substantially completed the bridge and thru lanes in 57 days. The intersection was reopened to traffic 46 days ahead of schedule.</p> <p>Delivering Project in a Developed Urban Corridor Route 29 is an urban other principal arterial and part of the National Highway System within a major commercial corridor. Large steel plates covered the initial utility and bridge/retaining wall foundation efforts performed each night. This is one of the major intersections that provides thru traffic on Route 29 major cross traffic with substantial turning movements in the center of a major commercial shopping district. Most initial construction was completed at night, including infrastructure and foundation for the bridge/retaining walls without impacting traffic during the day on Route 29 or Rio Road. Once the summer MOT was in place, the project team worked 24 hours a day, six days a week.</p>	<p align="center">Innovative Bridge Design Solutions/Construction Techniques</p> <p>Performed the structural engineering of the Rio Road Grade Separated Intersection via a design method that had never been constructed in Virginia. The abutments were integrally placed on top of the soldier pile retaining wall to minimize the bridge's footprint and allow Route 29 traffic to remain open throughout construction. The bridge superstructure was designed to act as a strut to support the retaining walls horizontally while supporting truck and roadway traffic vertically. This design concept was chosen due to the limited amount of space in the intersection and requirement to keep traffic open at all times during the project. The bridge and retaining walls were built in the congested intersection without acquiring additional right-of-way in an extremely tight schedule of 103 days allowable thru traffic restriction on Rio Road.</p> <p>The Rio Road Bridge design, using the bridge as a compression strut, reduced the number of piles required at the bridge abutments. Outside of the bridge limits, soldier pile walls were designed with a composite cast-in-place reinforced concrete wall having aesthetic treatments. Trumpets were installed for tiebacks in lieu of walers, which saved time during construction. Both designs enabled constructing abutments and wall piles at night and opened to traffic each morning. These innovations led to our team's low bid price, which was 30% lower than the next lowest bidder, providing tremendous value to the owner.</p>	<p align="center">Success in Coordinating Complex Utility Relocations</p> <p>There were utility relocations for Dominion, MCI, Century Link, Comcast, Fiberlight, Lumos, Quest Government, Quest Business, and City of Charlottesville Gas. Held utility coordination meetings with affected owners. To get a jump start, we relocated overhead/underground utilities while completing final design work. Early on, we shared design concepts, schedules, MOT Plans, and ROW processes and updates; requested their input/advice on how to avoid and/or relocate their facilities. At times, we performed a portion of their work to assist with on time delivery and to control costs.</p>	<p align="center">Awards Testimonials</p> <div style="display: flex; align-items: center;">  <ul style="list-style-type: none"> 2018 American Council of Engineering Companies of Virginia (ACEC) Engineering Excellence Award-Pinnacle Award 2018 Design-Build Institute of America Mid-Atlantic Region (DBIA-MAR) Design-Build Award 2018 Design-Build Institute of America Mid-Atlantic Region (DBIA-MAR) Design Build Excellence in Engineering Award </div> <p>Compliments from Dave Covington, VDOT's Regional Program Manager for Route 29 Solutions: <i>"Lane-Corman accomplished the work efficiently, quickly and most importantly, safely. We have a lot more work to do to complete this project, and the rest of the Route 29 Solutions program, but reopening the Rio Road intersection early was a major milestone accomplishment."</i></p> <p><i>LANE/CORMAN and RK&K did an excellent job of selecting the right design for a unique need, designing the bridge quickly to meet the needs of an aggressive schedule, working closely with VDOT to provide solutions for long-term maintenance and providing high quality design and construction."</i></p> <p>Compliment from VDOT Commissioner Charles Kilpatrick: <i>"The partnership between VDOT and Lane-Corman, as well as the cooperation of Albemarle County, the nearby businesses and neighborhoods and the community at large, were instrumental in the success of this project. Without the involvement of the businesses and the community – and their understanding for the inconveniences they experienced-we would not have attained this successful outcome."</i></p>
---	---	---	--	--	--

ATTACHMENT 3.4.1(a)
LEAD CONTRACTOR - WORK HISTORY FORM
(LIMIT 1 PAGE PER PROJECT)

a. Project Name & Location	b. Name of the prime design consulting firm responsible for the overall project design.	c. Contact information of the Client or Owner and their Project Manager who can verify Firm's responsibilities.	d. Contract Completion Date (Original)	e. Contract Completion Date (Actual or Estimated)	f. Contract Value (in thousands)		g. Dollar Value of Work Performed by the Firm identified as the Lead Contractor for this procurement.(in thousands)
					Original Contract Value	Final or Estimated Contract Value	
Name: Route 1 Tie-In Woodrow Wilson Bridge Urban Deck VA-4 Location: Alexandria, Virginia	Name: HNTB	Name of Client/ Owner: Virginia Dept. of Transportation Phone: 800-367-7623 Project Manager: Susan Shaw Phone: 571-221-5219 (mobile) Email: susan.shaw@vdot.virginia.gov	04/2008	04/2008	\$54,634	\$62,737 (Owner directed increase in scope due to plan revisions)	\$62,737

h. Narrative describing the Work Performed by the Firm identified as the Lead Contractor for this procurement. If the Offeror chooses to submit work completed by an affiliated or subsidiary company of the Lead Contractor, identify the full legal name of the affiliate or subsidiary and the role they will have on this Project, so the relevancy of that work can be considered accordingly. The Work History Form shall include only one singular project. Projects/contracts with multiple phases, segments, elements (projects), and/or contracts shall not be considered a single project. Projects/contracts with multiple phases, segments, elements (projects), and/or contracts shall not be claimed as a single project on this form. If the Offeror chooses to submit work performed as a Joint Venture or Partnership, identify how the Joint Venture or Partnership was structured and provide a description of the portion of the work performed only by the Offeror's firm.

RELEVANCY VDOT Design-Build Elements Survey Environmental Permitting Utility Relocations/Additions/Adjustments Roadway Construction Milling/Overlaying of Existing Pavement Bridge Demolition/Construction Guardrail/Barrier Signs/Sign Structures/Foundations Traffic Signal Overhead Sign Structures ITS Components including CCTV, and Fiber Optic Communications Infrastructure Lighting TMP/MOT Pavement Markings Storm Drainage Stormwater Management Facilities Stakeholder Coordination/Public Outreach Coordination with Adjacent Construction Projects	 <p><i>Urban deck swoop</i></p>	Corman Kokosing Role Brief Project Description Corman Kokosing was the prime contractor responsible for construction and proposed innovative, cost-effective value engineering. This was a two-phased, multi-level bridge, and roadway demolition/reconstruction project. Constructed the new South Washington Street Urban Deck Bridge over I-495, with its distinctive hour-glass design composed of three separate bridges, 280 ft. x 335 ft., built side-by-side and meticulously constructed in four quadrants to maintain South Washington Street traffic flow. There was 28,000 CY cast-in-place architecturally-finished structural concrete, 50 precast fascia panels on bridge, AASHTO girders and precast post and panel sound walls.	Success in Coordinating Complex Utility Relocations There was coordination with electric, sewer and water companies handled by Corman Kokosing in conjunction with VDOT's GEC representative. We coordinated with Alexandria City Sewer for relocations and new construction and coordinated tie ins with the owners. Daily coordination and weekly meetings discussed work plans and public information. We also installed a new storm drainage system in the footprint of the Beltway and along Washington Street.
TEAM MEMBERS ✓ Proposed DBPM Ryan Gorman, was the Project Manager ✓ Proposed Deputy DBPM Chris Rutkai was Sr. Project Engineer ✓ Proposed Superintendent Alvaro "Chico" Georgopoulos was a Foreman	I-95/I-495 Beltway in the densely-populated City of Alexandria. Original plans required the urban deck to be completed in five phases. One phase was a narrow middle phase which required S. Washington Street traffic to be in a split configuration. Corman Kokosing submitted a Value Engineering Proposal (VEP) to eliminate this phase from the urban deck construction sequencing without adversely affecting an adjacent cemetery. This resulted in a cost savings, was safer as traffic no longer had to be in a split formation, and a few weeks was saved due to more efficient work and one less traffic switch.	Accelerated Bridge Construction (ABC) Delivering Project in a Developed Urban Corridor This project widened ½-mile of the I-495 Beltway from the Route 1 Interchange to the Woodrow Wilson Bridge west abutment, and adjacent to the extremely congested	Awards Testimonials  2008 VDOT's Commitment to Excellence Award for Environmental Compliance Distinction, 1.24.08 2006 VDOT Commissioner's Award for Outstanding Achievement for the "Beltway Shift" -Innovation and Quality Improvement
nine months earlier making it independent of the other projects. Corman Kokosing planned and executed this traffic switch by closing the beltway to one lane at each direction. Close coordination and collaborative teamwork proved conducive in performing work each weekend ahead of schedule with minimal impact to the public.		Project was completed on schedule and on budget. All eight milestones were met. As a testament to quality, Corman Kokosing maintained a 99.29% C-36 Quality rating.	VDOT Representative's Remarks/Comments on a Form C-36 Final Performance Report: <i>"Corman Construction has consistently been ahead of their schedule. The contractor has proposed and VDOT has accepted two Value Engineering Proposals that have resulted in monetary savings. The Contractor overcame a major delay when vibrations resulting from installation of shoring, caused ceilings to collapse in adjacent apartment buildings. The delay to pile driving operations was almost three months due to this event. Corman was back on their original schedule within six months.</i>
Innovative Bridge Design Solutions/Construction Techniques Design-build elements used an augmented geotechnical investigation program to develop an innovative tie-in of an existing bridge on-ramp to the new I-95 alignment. This eliminated a design-build bridge from the existing Route 1 on-ramp bridge and replaced it with a low-density cementitious fill ramp.. This resulted in shortened construction, reduced cost and enhanced environmental stewardship.		And then there was the solution to separate schedule dependence from other Woodrow Wilson Bridge projects that became Corman Kokosing's crowning achievement. The award-winning two phase Virginia Advance Connector was constructed to the bridge by shifting the Capital Beltway, which allowed construction to commence on the north half	
This project widened ½-mile of the I-495 Beltway from the Route 1 Interchange to the Woodrow Wilson Bridge west abutment, and adjacent to the extremely congested		This review reflects final evaluation of the contractor for his performance on this project. Corman Construction, Inc. provided an impressive and outstanding performance in the execution of contract work. Performing some very heavy-duty construction (the Virginia abutment of the WWB) adjacent to high-rise towers on the one side and a cemetery on the other, in the middle of a residential area, clearly demonstrates the sensitivity of the stakes involved. But Corman management and field personnel seemed to have a good grasp on those stakes. The replacement of the Washington Street Bridge by the special design Urban Deck is another example. All things considered, Corman performed the project work with a very satisfactory quality, on budget, and with a slip in time that Corman was not responsible for. Corman's basic idea of diverting Beltway traffic under the Washington Street Bridge (known as the swoop) earned the project the Commissioner's 2006 Award for Outstanding Achievement, as well as the Governor's Award of Excellence. The \$46 M contract played a key part on the critical path of the WWB corridor construction, and Corman made sure that path was not jeopardized. Corman's record of environmental compliance and safety topped those of other VDOT contractors working on WWB. There were only two NOI's in the four-year life of the project that were addressed soon after onset. The courtesy, dedication, reliability and professionalism of contractor personnel score high marks. Corman management demonstrated partnering in candor and truthfully. VDOT/PCC construction management team appreciates and values this partnership."	

ATTACHMENT 3.4.1(a)

LEAD CONTRACTOR - WORK HISTORY FORM

(LIMIT 1 PAGE PER PROJECT)

a. Project Name & Location	b. Name of the prime design consulting firm responsible for the overall project design.	c. Contact information of the Client or Owner and their Project Manager who can verify Firm's responsibilities.	d. Contract Completion Date (Original)	e. Contract Completion Date (Actual or Estimated)	f. Contract Value (in thousands)		g. Dollar Value of Work Performed by the Firm identified as the Lead Contractor for this procurement.(in thousands)
					Original Contract Value	Final or Estimated Contract Value	
Name: Design-Build Rehabilitation of 11 Bridges On US 13 / 50 (Salisbury Bypass) Location: Wicomico County, Maryland	Name: RK&K	Name of Client/ Owner: Maryland Dept. of Transportation/State Highway Administration Phone: Project Manager: Glenn Evans Phone: 443-805-4979 Email: gevans8585@comcast.net	06/2018	06/2018	\$23,957	\$26,621 (Incentives for early completion)	\$26,621

h. Narrative describing the Work Performed by the Firm identified as the Lead Contractor for this procurement. If the Offeror chooses to submit work completed by an affiliated or subsidiary company of the Lead Contractor, identify the full legal name of the affiliate or subsidiary and the role they will have on this Project, so the relevancy of that work can be considered accordingly. The Work History Form shall include only one singular project. Projects/contracts with multiple phases, segments, elements (projects), and/or contracts shall not be considered a single project. Projects/contracts with multiple phases, segments, elements (projects), and/or contracts shall not be claimed as a single project on this form. If the Offeror chooses to submit work performed as a Joint Venture or Partnership, identify how the Joint Venture or Partnership was structured and provide a description of the portion of the work performed only by the Offeror's firm.

RELEVANCY

- Design-Build
- Survey
- Environmental Permitting
- Utility Coordination / Protection
- Roadway Construction
- Overlaying of Existing Pavement
- Bridge Demolition/Construction
- Barrier Walls
- Signs/Sign Structures/Foundations
- ITS
- Lighting
- TMP/MOT
- Pavement Markings
- Storm Drainage
- Stormwater Management Facilities
- QA/QC for design and construction
- Stakeholder Coordination/Public Outreach



Installing rebar at Pier and formwork

Corman Kokosing Role | Brief Project Description

Corman Kokosing as prime design-build contractor was responsible for design & construction. We self-performed maintenance of traffic (MOT) set up, removing concrete deck slabs and girders, reconstructing concrete pier caps, driving new piles at each abutment, forming/pouring new abutments, including footings, setting steel girders, pouring new concrete end slabs for the bridge

decks, latex overlay on the bridge's mid-spans, rehabilitating the barrier walls, installing/removing erosion & sediment controls, and restoring the median.

Accelerated Bridge Construction (ABC)

Phase 1 Milestone closed the US 13/50 westbound lanes and shifted traffic to the eastbound lanes leaving one lane going west/east on the east bound barrel of the divided highway. Bridge work had to be completed, roadway put back to its original configuration and the road and bridges opened to traffic by Memorial Day. Corman Kokosing completed this work one week ahead of schedule. Phase 2 Milestone closed the US 50 eastbound lanes and shifted the traffic to the westbound lanes leaving one lane going west and east to rehabilitate the eastbound bridges. Bridge work had to be completed, roadway put back to its original configuration and the road and bridges opened to traffic by the next Memorial Day. Corman Kokosing completed this work almost two months ahead of schedule. It was required to demolish the top portion of parapet walls on all bridges. Since specifications stated a hydraulic hammer could not be used, hand demolishing took place. To accelerate construction, Corman Kokosing came up with the idea to use a smaller excavator with a shear on it, which also produced a cost savings.

Delivering Project in a Developed Urban Corridor

Rehabilitated 11 40-year-old concrete and steel beamed bridges on heavily-traveled US 13/50 (Salisbury Bypass) which leads to Ocean City, MD, a popular vacation spot. Bridges are at the following locations along the northeastern section of the US 13/50 Bypass between the US 50/Business and US 13 Business interchanges: One ramp bridge from Route 13 Business to the Salisbury Bypass, two bridges at MD 346 (Old

Ocean City Road), two bridges at US 50/US 50 Business (Ocean Gateway), two bridges at MD 350 (Mount Hermon Road), two bridges at Norfolk Southern railroad, and two bridges over Parker Pond. Maintenance of traffic was critical with strict time-of-year restrictions on allowable work and traffic impacts. To maintain free flow, there were no lane closures during the busy summer tourist season and temporary detours only during the allowable work season to re-construct the bridges. This project was completed ahead of schedule.

Innovative Bridge Design Solutions/Construction Techniques

Seven bridges had unusual structural framing in the end spans. It was determined that the concrete end spans did not meet current bridge rating requirements and were to be replaced with steel beam end spans to match the interior spans of each bridge. This created an uncommon fixed-fixed condition for the rehabilitated end spans which required a 3D stiffness analysis to determine the effects on the bridge piers. The design-build team was responsible for rating the unusual new superstructure and existing substructure framing to ensure they met specifications. Through this analysis, it was proven that the spans met specifications, avoiding the need for further rehabilitation work that would have cost additional money and taken more time.

With a special MOT requirement for six of the 11 bridges limiting the time when traffic could be reduced to two lanes, the design-build team developed a complex two-phase approach to maintain traffic and repair the bridges. This involved four temporary crossovers and six temporary ramp connections at the US 50 interchange. Temporary crossover alternatives were developed and placed in locations of the median to minimize impacts to drainage structures and avoid environmental/tree impacts. Temporary crossover locations were also selected based on US 13's existing geometry where curves and super-elevation could be extended to reduce the crossover length as compared to the MOT concept in the RFP. Optional MOT phases were also designed to give Corman Kokosing more flexibility to continue work on bridges with no traffic restrictions and reuse temporary ramps as temporary crossovers south of the US 50 Interchange which reduced construction time and cost. In applying practical design, the shoulders were overlaid vs. reconstructed since less than 3 ft. of the shoulder was being used for MOT which resulted in additional savings and allowed a waiver for quantity and quality control for stormwater management.

Success in Coordinating Complex Utility Relocations

When constructing the temporary median crossovers for MOT, there were light poles, which we removed, and reconstructed after bridge work was completed. Traffic signs were adjusted and replace where necessary. Utilities at the crossings were protected.

Testimonials

Received an "A" for Contractor Administration, Personnel, Equipment, Partnering, and Public Relations; "A" in MBE/DBE/WBE Compliance; "A" in Quality of Work; "A" in Safety; "A" for Project on Schedule; an "A" for Environmental Stewardship; and "A" for Maintenance of Traffic. Corman Kokosing earned all erosion & sediment control incentives and the final schedule incentive for the project.

MDOT SHA Onsite Project Engineer Glenn Evans: "Corman personnel are great to work with. Corman workmanship and finished product meets all SHA standards and specifications. Communication and respect with SHA staff are excellent."

ATTACHMENT 3.4.1(b)

LEAD DESIGNER - WORK HISTORY FORM

(LIMIT 1 PAGE PER PROJECT)

a. Project Name & Location	b. Name of the prime/ general contractor responsible for overall construction of the project.	c. Contact information of the Client and their Project Manager who can verify Firm's responsibilities.	d. Construction Contract Start Date	e. Construction Contract Completion Date (Actual or Estimated)	f. Contract Value (in thousands)		g. Design Fee for the Work Performed by the Firm identified as the Lead Designer for this procurement.(in thousands)
					Construction Contract Value (Original)	Construction Contract Value (Actual or Estimated)	
Name: Route 7 (Leesburg Pike) over Dulles Toll Road (Route 267) and Airport Access Highway Widening and Bridge Rehabilitation Location: Fairfax County	Name: Wagman Heavy Civil, Inc.	Name of Client: VDOT: NOVA District Phone: (800) 367-7623 Project Manager: Vicente Valeza Jr. Phone: (703) 259-3256 Email: Vicente.Valeza@vdot.virginia.gov	07/2015	05/2018	\$39,887	\$42,197 <i>(Owner-directed changes)</i>	\$ 1,557 <i>(WRA Fee only for Bridge Engineering, Geotechnical, Noise Analysis/Mitigation, and Environmental support)</i>

h. Narrative describing the Work Performed by the Firm identified as the Lead Designer for this procurement. Include the office location(s) where the design work was performed and whether the firm was the prime designer or a subconsultant. The Work History Form shall include only one singular project. Projects/contracts with multiple phases, segments, elements (projects), and/or contracts shall not be considered a single project. Projects/contracts with multiple phases, segments, elements (projects), and/or contracts shall not be claimed as a single project on this form.



<p>RELEVANCY</p> <ul style="list-style-type: none"> ✓ VDOT Design-Build ✓ Located in Urban Corridor (Tysons, VA) ✓ Bridge Design, including construction support ✓ Roadway Design with vertical profile adjustments ✓ Environmental Permitting ✓ Utility Relocations/Additions/Adjustments ✓ Roadway Construction ✓ Milling/Overlaying and/or Building up of Existing Pavement ✓ Bridge Demolition/Construction ✓ Guardrail/Barrier ✓ Signs/Sign Structures/Foundations ✓ Overhead Sign Structures/Other Traffic Control Measures ✓ TMP/MOT ✓ QA/QC for design and construction ✓ Stakeholder Coordination/Public Outreach ✓ Raised Vertical Clearance from 14'-6" to 16'-6" <p>TEAM MEMBERS</p> <ul style="list-style-type: none"> ✓ Proposed DM Jeremy Schluskel was the Design Manager 	<p>WRA Role Brief Project Description</p> <p>The purpose of this \$42M project, located in Tysons Corner, Fairfax County, Virginia was to replace the superstructure, improve the vertical clearance and rehabilitate the existing SD substandard twin bridges carrying Route 7 (Leesburg Pike) over the Route 267 (Dulles Toll Road) and Dulles International Airport Access Highway (DIAAH) that were completed in 1963. As part of a DB Team, design staff from WRA Richmond, Fairfax and Baltimore offices were responsible for the Bridge and Geotechnical Engineering and Utility Coordination in association with structural elements.</p> <p>Accelerated Bridge Construction/Innovative Bridge Design Solutions/Construction Techniques/Delivering Project in a Developed Urban Corridor</p> <p>WRA was the EOR for bridge and geotechnical engineering for the superstructure replacement and widening and sub-structure rehabilitation. Urban Corridor: The two existing bridge structures, completed in 1963 carried over 60,000 vpd on two lanes of through traffic and one auxiliary lane and had a concrete sidewalk on each bridge; the WB bridge was identified as SD. The new widened superstructure upon completion matched the previously widened approach roadways and was designed and detailed as a single superstructure with eight lanes, a 14-foot shared use paths on each side and accommodations for a future CD lanes under the end spans. The new superstructure was raised 2 ft. to provide a 16'- 6" min. vertical clearance over the DTR and DIAAH through a combination of vertical profile change and higher strength structural steel (36 ksi vs 50 ksi). ABC & Innovation: The existing abutments were replaced using low overhead top down construction (micro-piles, see below) methods and the existing piers were widened and rehabilitated. To support the new superstructure, our analysis included review of the existing spread foundations for reuse, and design of micropiles, and driven H piles for the modified sub-structure elements. Specific sequencing was developed in order to load test the micropiles within the confines of the DTR median. The micropiles a deep-foundation solution due to low headroom and constrained work areas, were extremely beneficial in improving the constructability of the new bridge piers tightly constrained within the narrow median of the DTR and DIAAH. Construction Techniques: This minimized lane shifts and cut the number of construction phases in half from the RFP, greatly reducing impacts to these highly traveled roadways. In addition, during construction provided assistance relating to foundation installation and wall construction and subgrade preparation.</p>	<p>Success in Coordinating Complex Utility Relocations</p> <p>During the concept design development, our team evaluated the RFP design for improvements and enhancements associated with the proposed superstructure replacement, soundwalls and pedestrian bridge structures as the utilities added significant unpredictability to the project schedule. The main areas of focus were the existing third-party fiber optic cables (from numerous providers under numerous permits) attached to the existing bridge that had to remain in service. In addition, having Metro Rail in the area, added additional uncertainties with respect to their infrastructure. Our team used the Proprietary Meeting process to vet design ideas that we believed improved the design, reduced costs, reduced major utility impacts, provided safer passage of pedestrians, and reduced future maintenance costs for the owners. These were significant changes that were outside the scope of the RFP, but subsequently then incorporated into the RFP for all three proposers to develop their bids based on the obvious benefit. The original design provided underpasses (tunnels) at ramp crossings in the NW, NE, and SE quadrants of the interchange. To reduce the impacts, WRA proposed and ultimately designed a pedestrian bridge in the SE quadrant eliminating the underpass and its impacts. This change was significant because if the underpass was kept in the SE quadrant it would have impacted a large traction power system for the Metro Rail and added millions of dollars to the Project cost as well as significantly impacted the schedule. The DBT provided several enhancements included in the low price proposal. The most notable was in terms of mitigation of potential utility delays and compression of the project schedule. The DBT proposal reduced the construction phasing of the bridge replacement from seven phases to four phases. This was achieved by adjusting the bridge alignment and constructing the northern widening in the first phase concurrent with the interior widening. This also allowed the DBT to provide a corridor for the utilities to relocate eight months ahead of the RFP documents in order to maximize the schedule float available to the utility providers. The DBT also included self-performing construction of the new utility duct bank in the proposal to mitigate potential schedule impacts by utility construction crews. Through teamwork and communication, all traffic was maintained in accordance with the RFP requirements while reducing the number of construction stages. The reduction in construction stages also reduced utility relocations costs. The DBT accommodated the request of a politically active and litigious home owners association, whose ROW was required to facilitate the construction of a new noise barrier. In addition to ROW, the new noise barrier required the relocation of existing overhead high voltage power lines. The DBT and VDOT developed an alternate design concept to eliminate the need to install poles and ground wires into a common area that was highly used for recreation. This required the third-party utility owner to implement non-standard details and was accomplished without impacting the project schedule.</p> <p>Awards Testimonials</p> <p> This project upon completion was awarded the 2019 DBIA Mid-Atlantic Merit Award and the 2019 HCCA (Heavy Construction Contractors Association) Excellence in Infrastructure Award for projects over \$15M.</p>	<p align="center"><i>Route 7 over Dulles Toll Road (Route 267) and Airport Access Highway</i></p> 
--	--	---	--

ATTACHMENT 3.4.1(b)

LEAD DESIGNER - WORK HISTORY FORM

(LIMIT 1 PAGE PER PROJECT)

a. Project Name & Location	b. Name of the prime/ general contractor responsible for overall construction of the project.	c. Contact information of the Client and their Project Manager who can verify Firm's responsibilities.	d. Construction Contract Start Date	e. Construction Contract Completion Date (Actual or Estimated)	f. Contract Value (in thousands)		g. Design Fee for the Work Performed by the Firm identified as the Lead Designer for this procurement.(in thousands)
					Construction Contract Value (Original)	Construction Contract Value (Actual or Estimated)	
Name: Route 173 (Denbigh Blvd.) over I-64 and CSXT Bridge Replacement and Widening Location: City of Newport News, VA	Name: Corman Kokosing Construction Company	Name of Client: VDOT: Hampton Roads District Phone: (757) 956-3000 Project Manager: Paul Sudol, P.E. Phone: (315) 726-1090 (mobile) Email: paul.sudol@vdot.virginia.gov	07/2019	07/2021	\$22,963	\$22,963	\$ 2,106 (includes Stage 3 Construction Engineering Support)
h. Narrative describing the Work Performed by the Firm identified as the Lead Designer for this procurement. Include the office location(s) where the design work was performed and whether the firm was the prime designer or a subconsultant. The Work History Form shall include only one singular project. Projects/contracts with multiple phases, segments, elements (projects), and/or contracts shall not be considered a single project. Projects/contracts with multiple phases, segments, elements (projects), and/or contracts shall not be claimed as a single project on this form.							

RELEVANCY	WRA Role Brief Project Description	Success in Coordinating Complex Utility Relocations
<ul style="list-style-type: none"> ✓ Accelerated Bridge Construction ✓ Located in Urban Corridor (I-64 – Hampton Roads District) ✓ Limited impact to traveling public ✓ Innovative design – Prefabricated Retaining Wall Elements ✓ Innovative Design – Geofoam Blocks used to eliminate need for settlement time of approach roadway ✓ Raised Vertical Clearance from 22'-0" to 24'-11" over CSXT and 17'-9 to 18'-3 over I-64 – allows for future widening of I-64 and additional track on CSXT ✓ MOT and Interstate Lane Closures for Overhead Work ✓ Staged Construction ✓ Traffic Control Devices ✓ TMP ✓ Utility Relocation/Coordination ✓ Geotechnical ✓ Hydraulics and SWM ✓ Public Involvement/Communications ✓ QA/QC ✓ Construction Engineering Support ✓ Original Bridge Construction from same era as bridges on this 	<p>The purpose of this \$23M project, located in Newport News, VA is to replace the existing 900 ft. bridge completed in 1964 due to its sub-standard vertical clearance over the railroad, significant settlement/geotechnical issues with the approach roadway and foundations and due to the overall SD condition rating. The WRA Richmond Office was responsible for all design elements for the project with design support from subconsultant, Athavale, Lystad & Associates, Inc.; Corman Kokosing is the Contractor.</p> <p>Accelerated Bridge Construction/ Innovative Bridge Design Solutions/Construction Techniques/Delivering Project in a Developed Urban Corridor</p> <p>The original bridge structure consisted of twelve (12) simple structural steel beam spans that range in length from 43 ft. to 105 ft. for a total bridge length of approximately 850 ft. The original substructure consisted of multi-column piers/solid wall piers supported by either individual column footings or pile caps and the abutments were stub abutments with "U-back" wingwalls. In 1964, the approach roadway underwent a shear failure along the west approaches of Denbigh Boulevard in trying to construct the approximately 33 ft. tall fill sections. The failure caused settlement of approximately 8 to 10 feet for 350 ft. along the west approach. Due to this failure, the existing clay layer was weakened and, after various studies were conducted, the original design plans were modified to span over the shear failure. Since the completion of the project in the 1960s, settlement has been an on-going issue for this roadway and bridge structure. Urban Corridor - With Denbigh Blvd carrying over 31,000 vpd on the roadway and this being a major crossing of I-64 and CSXT in the City of Newport News, maintaining the traffic was critical for the flow between Jefferson Ave. and Warwick Blvd. WRA traffic engineers and roadway engineers reviewed multiple options from building off alignment, complete closure, and staged construction and through a WZIA and working with the City and local businesses, determined that maintaining 2 lanes of traffic with diversions to other roadways would provide an acceptable level of services for the duration of the project. To account for the geotechnical issues, and to reduce the project timeline to account for settlement for the proposed widening, WRA Bridge and Geotechnical Engineers designed and detailed innovative solutions to address the weakened clay layers at this site. The final layout recommended a replacement bridge structure that stayed in the same the same 85 ft. right-of-way corridor with a slight shift in the horizontal alignment toward the south to accommodate a two-stage sequence of construction. The new bridge design meets current design standards and will be built at an elevation that will accommodate the required vertical clearances over CSXT property and the future widening of I-64. The new bridge will consist of 6 spans for a total bridge length of 909'-9". The 85-inch bulb-tees will support four 12-foot lanes, a 16-foot raised median, and two 8-foot sidewalks with architectural treatments along the retaining walls and bridge parapet. The piers are a combination of wall piers and multi-column piers and the abutments are VA Abutments, all are supported by deep pile foundations. The final design incorporated:</p> <ul style="list-style-type: none"> • Innovative Bridge Design - Lightweight Concrete in all Beams and Superstructure elements to reduce Dead Loads • Accelerated Bridge Construction and Innovative Bridge Design - Geofoam in the approach roadway fill to reduce construction duration (not having to wait for settlement) and reduce the potential for long term settlement • Accelerated Bridge Construction and Innovative Bridge Design - Precast Retaining Wall Sections with Geofoam Blocks to reduce time required to back-fill and compact fill material and construct the retaining walls 	<p>During the development of this project, there were overhead power and communication lines and buried water and gas lines and numerous storm and sanitary line conflicts. Working with our design team, WRA and VDOT worked together to successfully move the elements in conflict ahead of the project. A key element in the success of the utility relocation work was during design to review potential crane placements for impacts and evaluation of the substructure locations.</p> <p>Awards Testimonials</p> <p> January 2021 Consultant Evaluation said "WRA has met or exceeded expectations in all categories. WRA has provided outstanding support throughout the duration of a project that has required addressing and resolving several challenging construction/constructability issues. Regardless of the issue or situation, WRA's Management Team has always been responsive and effectively managed the personnel, resources, budget and schedule for the Project. They have worked extremely well with VDOT, the Contractor, and other consultant staff and have maintained timely and appropriate responses to RFIs and submittals. WRA consistently meets the expectation of the Department's Construction Staff in providing Construction Phase Services on the Project. WRA's responses to Submittals and RFIs clearly indicate that WRA employs a comprehensive QA/QC program as a key element of providing professional engineering services. WRA has been extremely flexible and cooperative in working with the Department, the Contractor and other stakeholders. They have been proactive in identifying and working with the Department to address and resolve construction and constructability issues."</p>
TEAM MEMBERS	 <p align="center"><i>Route 173 (Denbigh Blvd.) over I-64 and CSXT</i></p>	
<ul style="list-style-type: none"> ✓ Proposed DM Jeremy Schlussel was the Design Manager 		

ATTACHMENT 3.4.1(b)

LEAD DESIGNER - WORK HISTORY FORM

(LIMIT 1 PAGE PER PROJECT)

a. Project Name & Location	b. Name of the prime/ general contractor responsible for overall construction of the project.	c. Contact information of the Client and their Project Manager who can verify Firm's responsibilities.	d. Construction Contract Start Date	e. Construction Contract Completion Date (Actual or Estimated)	f. Contract Value (in thousands)		g. Design Fee for the Work Performed by the Firm identified as the Lead Designer for this procurement.(in thousands)
					Construction Contract Value (Original)	Construction Contract Value (Actual or Estimated)	
Name: I-95 (NB & SB) over Route 608 (Reymet Road) Location: Chesterfield County, VA	Name: TBD – Project is out to bid with a let date of 2/24/21	Name of Client: VDOT: Richmond District Phone: (804) 524-6000 Project Manager: Mr. Jeff Hill, P.E. Phone: (804) 720-6616 (mobile) Email: jeff.hill@vdot.virginia.gov	02/2021 (Let Date)	07/2022 (Contract Date)	TBD	Est. per CABB = \$9,409	\$821

h. Narrative describing the Work Performed by the Firm identified as the Lead Designer for this procurement. Include the office location(s) where the design work was performed and whether the firm was the prime designer or a subconsultant. The Work History Form shall include only one singular project. Projects/contracts with multiple phases, segments, elements (projects), and/or contracts shall not be considered a single project. Projects/contracts with multiple phases, segments, elements (projects), and/or contracts shall not be claimed as a single project on this form.

RELEVANCY

- ✓ Accelerated Bridge Construction
- ✓ Located in Urban Corridor (I-95 – Richmond District)
- ✓ Limited impact to traveling public
- ✓ Innovative design – Prefabricated Bridge Units (PBU's) with two layout options
- ✓ Raised Vertical Clearance from 14'-4" to 15'-0"
- ✓ MOT and Interstate Lane Closures
- ✓ Weekend Only Closures/Shifts for Major Work Elements
- ✓ Traffic Control Devices
- ✓ TMP
- ✓ Utility Relocation/Coordination
- ✓ Geotechnical
- ✓ Hydraulics and SWM
- ✓ Public Involvement/Communications
- ✓ QA/QC
- ✓ Construction Engineering Support
- ✓ Existing Bridge Construction from same era as bridges on this proposed project

TEAM MEMBERS

- ✓ Proposed DM Jeremy Schlüssel was the Design Manager

WRA Role | Brief Project Description
Under multiple VDOT S&B On-Call Contract, WRA Richmond office has designed over \$200M in construction projects, WRA was assigned the a complete field evaluation (with material testing) and design services for the replacement of I-95 (NB/SB) over Route 608 (Reymet Road) superstructure to remove the SD designation from this bridge structure. The original bridge was completed in 1958 as part of the original Richmond-Petersburg Turnpike and was widened in 1977 and in 1990 to accommodate the widening of I-95. WRA Richmond Office provided bridge design, highway design, hydrologic and hydraulic design, stormwater management (SWM) design, erosion and sediment control design, geotechnical engineering, pavement evaluation and design, maintenance of traffic, signing & pavement markings.

Accelerated Bridge Construction/ Innovative Bridge Design Solutions/Construction Techniques/Delivering Project in a Developed Urban Corridor
To reduce the impacts on I-95, various ABC options were reviewed, including slide-in options and deck panels; ultimately, the Prefabricated Bridge Units (PBU) was chosen as the best alternative. **Accelerated Bridge Construction:** The units designed and detailed provided variable width PBUs using the same girder design for new superstructure layout to miss the existing beam lines to reduce conflicts during the placement of the PBUs on designated weekends. **Innovation:** To account for the approach slabs with ABC construction, WRA designed and detailed the use of stainless steel corbel brackets to support the new buried pre-cast approach slab. The brackets will be installed on the back of the backwall during the long weekend closures and each unit was detailed to match up with the sequence of construction on the PBUs. Roadway – The proposed improvements on the approaches will remove and replace approximately 200 feet of approach roadway and will be coordinated with the weekend closures. Roadway improvements include full depth pavement, permanent median barrier, and guardrail. **Innovation and Construction Techniques:** Slopes beyond the guardrail were steepened using geosynthetic layers to avoid impacts to right-of-way. **Innovation:** SWM/Drainage requirements were evaluated and the final design eliminated the need for any ponds and rehabilitated existing facilities to ensure water was channeled to the existing elements in-place.

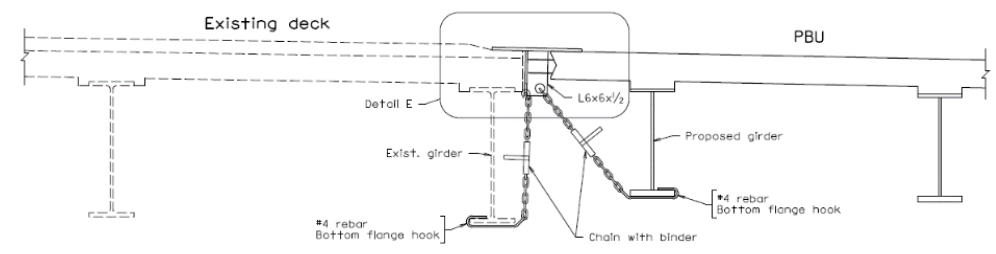

Section between Existing Deck and PBU during staged construction

Project in Urban Corridor: A Work Zone Traffic Impact Assessment (WZTIA) was performed for the replacement of the I-95 bridge over Reymet Road to understand the impacts to the over 100,000 vpd along this corridor. The analysis included a comparison of various lane closure scenarios for various time periods (i.e., weekend, weekday, off-peak, etc.) to determine the impact on the traveling public including queues and delays. Multiple diversion scenarios were considered to establish a range of potential queues and delays. The analysis concluded that multiple weekend single lane closures while maintaining four travel lanes on I-95 was the recommended alternative to minimize impacts to the traveling public while providing sufficient work area and duration to conduct the bridge construction activities. In addition, a Highway User Benefit-Cost Analysis Program (HUBCAP) analysis was performed to estimate user costs associated with the lane closures on I-95 considering various factors associated with construction impacts including lane width reductions, speed limit reductions, and diversion percentages. Multiple scenarios were analyzed including single lane closures, double lane closures, and 0% versus 15% diversion to alternate routes in order to establish a reasonable user benefit cost. Using this information, two scenarios were detailed: Option 1 – traffic is reduced and shifted within the NB and or SB lanes to maintain 4 lanes or Option 2 – traffic is detoured from NB to SB / SB to NB using moveable barrier and four lanes of traffic are maintained during the long weekends. In both options, a dynamic speed limit will be used to reduce the speed limits during weekend construction.

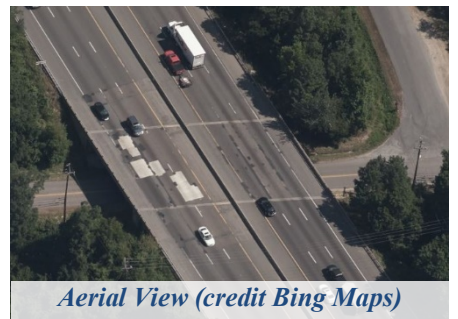

Success in Coordinating Complex Utility Relocations
As part of this project, there were two utilities, which required coordinating. One was a VDOT owned utility for power that required coordination to maintain power to an overhead sign structure north of the project site. The other utility was an overhead power line that crossed within zone of potential influence for cranes. Working with the designers, WRA was able to successfully show crane placements and how our design for placement of mobile cranes outside of this influence, thus reduced project costs and time.

Awards | Testimonials
The Richmond District PM, Mr. Jason Zhang, P.E. commented that after review was complete of the final plans on 7/1/2020 via e-mail that the comments received “are the fewest I have ever seen so excellent job from your team”.



